

## Some Application of Trigonometry

1. (A) The shadow of a tower standing on a level ground is found to be 40 m longer when the Sun's altitude is  $30^\circ$  than when it was  $60^\circ$ . Find the height of the tower and the length of original shadow. (use  $\sqrt{3} = 1.73$ ) (2024)

**Answer.** (A) Let AB be the tower and AC and AD are shadows.

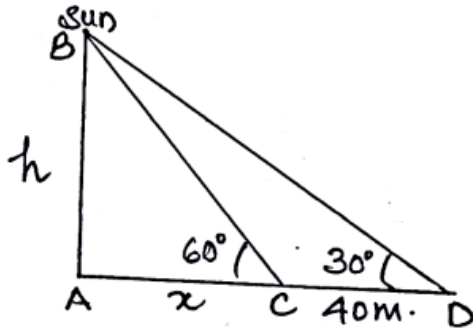

$$\text{In } \triangle BAD, \tan 30^\circ = \frac{h}{x+40} \Rightarrow \frac{1}{\sqrt{3}} = \frac{h}{x+40}$$

$$\Rightarrow x+40 = h\sqrt{3} \text{ _____ (i)}$$

$$\text{In } \triangle BAC, \tan 60^\circ = \frac{h}{x} \Rightarrow \sqrt{3} = \frac{h}{x} \Rightarrow h = x\sqrt{3} \text{ _____ (ii)}$$

$$\text{From (i) and (ii) } h = 20\sqrt{3} = 34.6 \text{ m}$$

And  $x = 20$

length of original shadow = 20 m, height = 34.6 m.

OR

(B) The angles of depression of the top and the bottom of an 8 m tall building from the top of a multi-storeyed building are  $30^\circ$  and  $45^\circ$  respectively. Find the height of the multi-storeyed building and the distance between the two buildings. (use  $\sqrt{3} = 1.73$ ) (2024)

**Answer.** Let CD and AB are buildings

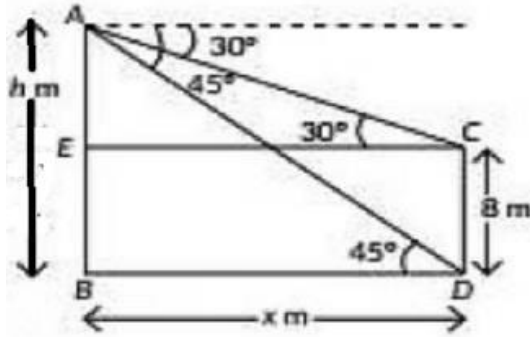

Correct figure 1

$$\text{In } \triangle AEC, \tan 30^\circ = \frac{h-8}{x} \Rightarrow h-8 = \frac{x}{\sqrt{3}} \text{ ——— (i)}$$

$$\text{In } \triangle ABD, \tan 45^\circ = \frac{h}{x} \Rightarrow h = x \text{ ——— (ii)}$$

Solving (i) and (ii)  $h = x = 12 + 4\sqrt{3} = 18.92 \text{ m.}$

2. A pole 6m high is fixed on the top of a tower. The angle of elevation of the top of the pole observed from a point P on the ground is  $60^\circ$  and the angle of depression of the point P from the top of the tower is  $45^\circ$ . Find the height of the tower and the distance of point P from the foot of the tower. (Use  $\sqrt{3} = 1.73$ ) (2024)

Answer.

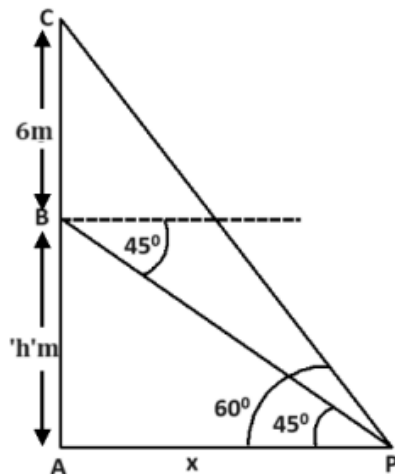

Let BC be the pole and AB be the tower of height 'h' m.

$$\tan 45^\circ = 1 = \frac{h}{x}$$

$$\Rightarrow h = x \text{ ---- (i)}$$

$$\tan 60^\circ = \sqrt{3} = \frac{h + 6}{x}$$

$$\Rightarrow h + 6 = x\sqrt{3} \text{ ---- (ii)}$$

Solving (i) & (ii) to get

$$h = 3(\sqrt{3} + 1) = 8.19$$

and  $x = 8.19$

Therefore, the height of tower is 8.19 m and the distance of point P from the foot of the tower is 8.19 m

## 9.1 Heights and Distances

### MCQ

1. If a pole 6 m high casts a shadow  $2\sqrt{3}$  m long on the ground, then sun's elevation is
  - (a)  $60^\circ$
  - (b)  $45^\circ$
  - (c)  $30^\circ$
  - (d)  $90^\circ$  (2023)
2. A ladder makes an angle of  $60^\circ$  with the ground when placed against a wall. If the foot of the ladder is 2 m away from the wall, then the length of the ladder (in meters) is
3. The angle of depression of a car parked on the road from the top of a 150 m high tower is  $30^\circ$ . The distance of the car from the tower (in metres) is
  - (a)  $50\sqrt{3}$
  - (b)  $150\sqrt{3}$
  - (c)  $150\sqrt{2}$
  - (d) 75 (AI 2014)
4. If the height of a vertical pole is  $\sqrt{3}$  times the length of its shadow on the ground, then the angle of elevation of the Sun at that time is
  - (a)  $30^\circ$
  - (b)  $60^\circ$
  - (c)  $45^\circ$
  - (d)  $75^\circ$  (Foreign 2014)

**VSA (1 mark)**

5. In figure, the angle of elevation of the top of a tower from a point C on the ground, which is 30 m away from the foot of the tower, is  $30^\circ$ . Find the height of the tower.

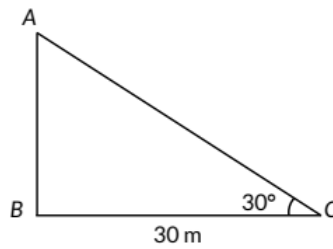

(2020)

6. The ratio of the length of a vertical rod and the length of its shadow is  $1:\sqrt{3}$ . Find the angle of elevation of the Sun at that moment. (2020)

7. The ratio of the height of a tower and the length of its shadow on the ground is  $\sqrt{3}:1$ . What is the angle of elevation of the sun? (Delhi 2017)

8. If a tower 30 m high, casts a shadow  $10\sqrt{3}$  m long on the ground, then what is the angle of elevation of the sun? (AI 2017)

9. In the given figure, AB is a 6 m high pole and CD is a ladder inclined at an angle of  $60^\circ$  to the horizontal and reaches up to a point D of pole. If  $AD = 2.54$  m, find the length of the ladder. (Use  $\sqrt{3}=1.73$ )

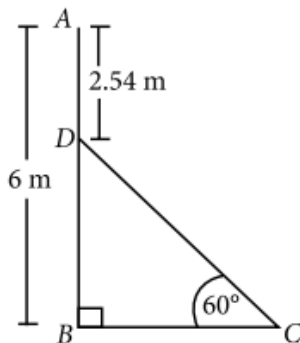

(Delhi 2016)

10. A ladder, leaning against a wall, makes an angle of  $60^\circ$  with the horizontal. If the foot of the ladder is 2.5 m away from the wall, find the length of the ladder. (AI 2016)

11. An observer, 1.7 m tall, is  $20\sqrt{3}$  m away from a tower. The angle of elevation from the eye of observer to the top of tower is  $30^\circ$ . Find the height of the tower. (Foreign 2016)

12. The tops of two towers of height  $x$  and  $y$ , standing on level ground, subtend angles of  $30^\circ$  and  $60^\circ$  respectively at the centre of the line joining their feet, then find  $x:y$ . (Delhi 2015)

13. In the given figure, a tower  $AB$  is 20 m high and  $BC$ , its shadow on the ground, is  $20\sqrt{3}$  m long. Find the Sun's altitude.

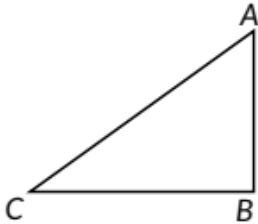

(AI 2015)

14. A pole casts a shadow of length  $2\sqrt{3}$  m on the ground, when the sun's elevation is  $60^\circ$ . Find the height of the pole. (Foreign 2015)

**SAI (2 marks)**

15. The rod  $AC$  of a TV disc antenna is fixed at right angles to the wall  $AB$  and a rod  $CD$  is supporting the disc as shown in the figure. If  $AC = 1.5$  m long and  $CD = 3$  m, then find

(i)  $\tan \theta$

(ii)  $\sec \theta + \csc \theta$

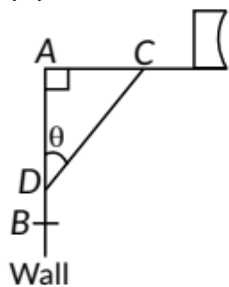

(2020) 

**SA II (3 marks)**

16. Two boats are sailing in the sea 80 m apart from each other towards a cliff  $AB$ . The angles of depression of the boats from the top of the cliff are  $30^\circ$  and

$45^\circ$  respectively, as shown in figure. Find the height of the cliff.

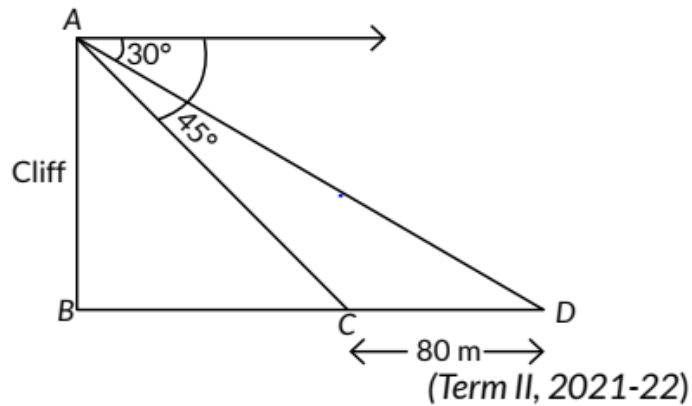

17. The angle of elevation of the top of a building from the foot of the tower is  $30^\circ$  and the angle of elevation of the top of the tower from the foot of the building is  $60^\circ$ . If the tower is 50 m high, then find the height of the building. (Term II, 2021-22)

18. In figure, AB is tower of height 50 m. A man standing on its top, observes two cars on the opposite sides of the tower with angles of depression  $30^\circ$  and  $45^\circ$  respectively. Find the distance between the two cars.

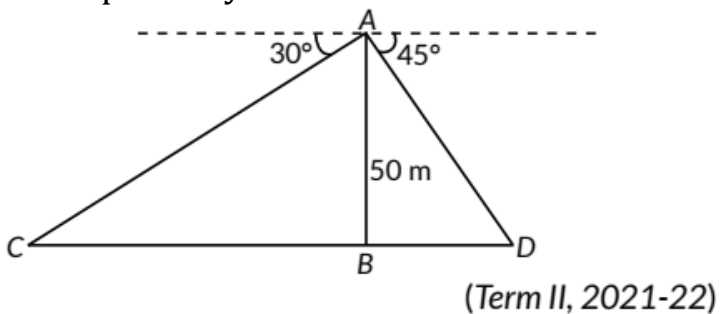

19. An aeroplane when flying at a height of 3125 m from the ground passes vertically below another plane at an instant when the angles of elevation of the two planes from the same point on the ground are  $30^\circ$  and  $60^\circ$  respectively. Find the distance between the two planes at that instant. (Term II, 2021-22)

20. The shadow of a tower standing on a level ground is found to be 40 m longer when the Sun's altitude is  $30^\circ$  than when it is  $60^\circ$ . Find the height of the tower. (Term II, 2021-22 C)

21. The tops of two poles of heights 20 m and 28 m are connected with a wire. The wire is inclined to the horizontal at an angle of  $30^\circ$ . Find the length of the wire and the distance between the two poles. (Term II, 2021-22)

22. Two men on either side of a cliff 75 m high observe the angles of elevation of the top of the cliff to be  $30^\circ$  and  $60^\circ$ . Find the distance between the two men.

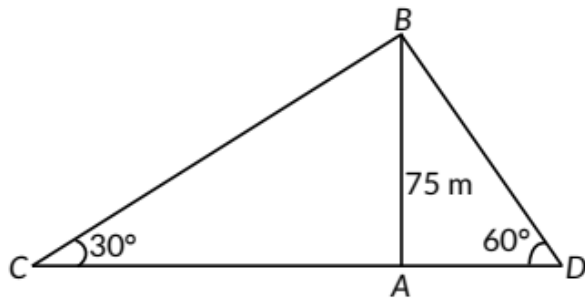

(Term II, 2021-22)

OR

Two men on either side of a 75 m high building and in line with base of building observe the angles of elevation of the top of the building as  $30^\circ$  and  $60^\circ$ . Find the distance between the two men. (Use  $\sqrt{3}=1.73$ ) (Foreign 2016)

23. From a point on a bridge across a river, the angles of depression of the banks on opposite sides of the river are  $30^\circ$  and  $45^\circ$ . If the bridge is at a height of 8 m from the banks, then find the width of the river.

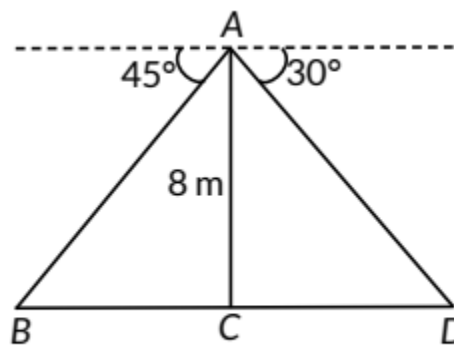

(Term II, 2021-22) 

24. A moving boat is observed from the top of a 150 m high cliff moving away from the cliff. The angle of depression of the boat changes from  $60^\circ$  to  $45^\circ$  in 2 minutes. Find the speed of the boat in m/h. (Delhi 2017)

25. From the top of a 7 m high building, the angle of elevation of the top of a tower is  $60^\circ$  and the angle of depression of its foot is  $45^\circ$ . Find the height of the tower. (NCERT Exemplar, Delhi 2017)



26. A man standing on the deck of a ship, which is 10 m above water level, observes the angle of elevation of the top of a hill as  $60^\circ$  and the angle of depression of the base of hill as  $30^\circ$ . Find the distance of the hill from the ship and the height of the hill. (AI 2016)

27. The angles of depression of the top and bottom of a 50 m high building from the top of a tower are  $45^\circ$  and  $60^\circ$  respectively. Find the height of the tower and the horizontal distance between the tower and the building. (Use  $\sqrt{3}=1.73$ ) (Delhi 2016)

28. A 7 m long flagstaff is fixed on the top of a tower standing on the horizontal plane. From a point on the ground, the angles of elevation of the top and bottom of the flagstaff are  $60^\circ$  and  $45^\circ$  respectively. Find the height of the tower correct to one place of decimal. (Use  $\sqrt{3}=1.73$ ) (Foreign 2016)

29. An aeroplane, when flying at a height of 4000 m from the ground passes vertically above another aeroplane at an instant when the angles of elevation of the two planes from the same point on the ground are  $60^\circ$  and  $45^\circ$  respectively. Find the vertical distance between the aeroplanes at that instant. (Take  $\sqrt{3}=1.73$ ) (Foreign 2016)

30. The angle of elevation of the top of a building from the foot of the tower is  $30^\circ$  and the angle of elevation of the top of the tower from the foot of the building is  $45^\circ$ . If the tower is 30 m high, find the height of the building. (Delhi 2015)

31. The angle of elevation of an aeroplane from a point A on the ground is  $60^\circ$ . After a flight of 15 seconds, the angle of elevation changes to  $30^\circ$ . If the aeroplane is flying at a constant height of  $1500\sqrt{3}$  m, find the speed of the plane in km/hr. (AI 2015)

32. From the top of a tower of height 50 m, the angles of depression of the top and bottom of a pole are  $30^\circ$  and  $45^\circ$  respectively. Find  
(i) how far the pole is from the bottom of a tower,  
(ii) the height of the pole. (Use  $\sqrt{3}=1.732$ ) (Foreign 2015)

33. Two ships are there in the sea on either side of a light house in such a way that the ships and the light house are in the same straight line. The angles of depression of two ships as observed from the top of light house are  $60^\circ$  and

45°. If the height of the light house is 200 m, find the distance between the two ships. [Use  $\sqrt{3}=1.73$ ] (Delhi 2014)

34. The angle of elevation of an aeroplane from a point on the ground is  $60^\circ$ . After a flight of 30 seconds the angle of elevation becomes  $30^\circ$ . If the aeroplane is flying at a constant height of  $3000\sqrt{3}$  m, speed of the aeroplane. find the (AI 2014)

35. From the top of a 60 m high building, the angles of depression of the top and the bottom of a tower are  $45^\circ$  and  $60^\circ$  respectively. Find the height of the tower. [Take  $\sqrt{3}=1.73$ ] (AI 2014)

36. Two ships are approaching a light-house from opposite directions. The angles of depression of the two ships from the top of the light-house are  $30^\circ$  and

$45^\circ$ . If the distance between the two ships is 100 m, find the height of the light-house. [Use  $\sqrt{3}=1.732$ ] (Foreign 2014)

#### LA (4/5/6 marks)

37. A straight highway leads to the foot of a tower. A man standing on the top of the 75 m high observes two cars at angles of depression of  $30^\circ$  and  $60^\circ$  which are approaching the foot of the tower. If one car is exactly behind the other on the same side of the tower, find the distance between the two cars. (Use  $\sqrt{3}=1.73$ ) (2023)

38. From the top of a 7 m high building the angle of elevation of the top of a cable tower is  $60^\circ$  and the angle of depression of its foot is  $30^\circ$ . Determine the height of the tower. (2023)

39. A ladder set against a wall at an angle  $45^\circ$  to the ground. If the foot of the ladder is pulled away from the wall through a distance of 4 m, its top slides a distance of 3 m down the wall making an angle  $30^\circ$  with the ground. Find the final height of the top of the ladder from the ground and length of the ladder. (2023)

40. The angle of elevation of the top Q of a vertical tower PQ from a point X on the ground is  $60^\circ$ . From a point Y, 40 m vertically above X, the angle of elevation of the top Q of tower is  $45^\circ$ . Find the height of the tower PQ and the distance PX. (Use  $\sqrt{3}=1.73$ ) (Term II, 2021-22, AI 2016)

41. The straight highway leads to the foot of a tower. A man standing at the top of the tower observes a car at an angle of depression of  $30^\circ$ , which is approaching the foot of the tower with a uniform speed. Ten seconds later the angle of depression of the car is found to be  $60^\circ$ . Find the time taken by the car to reach the foot of the tower from this point. (Term II, 2021-22)

42. Case Study: Kite festival

Kite festival is celebrated in many countries at different times of the year. In India, every year 14th January is celebrated as International Kite Day. On this day many people visit India and participate in the festival by flying various kinds of kites. The picture given below, shows three kites flying together.

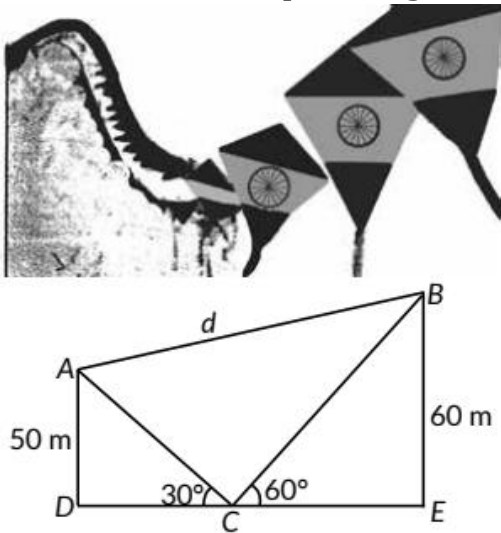

In Fig. the angles of elevation of two kites (Points A and B) from the hands of a man (Point C) are found to be  $30^\circ$  and  $60^\circ$  respectively. Taking  $AD = 50$  m and  $BE = 60$  m, find

(i) the lengths of strings used (take them straight) for kites A and B as shown in figure.

(ii) the distance 'd' between these two kites. (Term II, 2021-22)

43. A man on the top of a vertical tower observes a car moving at a uniform speed coming directly towards it. If it takes 18 minutes for the angle of depression to change from  $30^\circ$  to  $60^\circ$ , how soon after this will the car reach the tower? (2021 C)

44. A girl on a ship standing on a wooden platform, which is 50 m above water level, observes the angle of elevation of the top of a hill as  $30^\circ$  and the angle of

depression of the base of the hill as  $60^\circ$ . Calculate the distance of the hill from the platform and the height of the hill. (2021 C)

45. From a point on the ground, the angles of elevation of the bottom and the top of a transmission tower fixed at the top of a 20 m high building are  $45^\circ$  and  $60^\circ$  respectively. Find the height of the tower. (Use  $\sqrt{3} = 1.73$ ) (2020)

46. A statue 1.6 m tall, stands on the top of a pedestal. From a point on the ground the angle of elevation of the top of the statue is  $60^\circ$  and from the same point the angle of elevation of the top of the pedestal is  $45^\circ$ . Find the height of the pedestal. (Use  $\sqrt{3} = 1.73$ ) (NCERT, 2020) Ap

47. The angles of depression of the top and bottom of a 8 m tall building from the top of a tower are  $30^\circ$  and  $45^\circ$  respectively. Find the height of the tower and the distance between the tower and the building. (2019C)

48. As observed from the top of a lighthouse, 75 m high from the sea level, the angles of depression of two ships are  $30^\circ$  and  $45^\circ$ . If one ship is exactly behind the other on the same side of the lighthouse, find the distance between the two ships. (2019C)

49. A man in a boat rowing away from a light house 100 m high takes 2 minutes to change the angle of elevation of the top of the light house from  $60^\circ$  to  $30^\circ$ . Find the speed of the boat in metres per minute. [Use  $\sqrt{3}=1.732$ ] (Delhi 2019)

50. Amit, standing on a horizontal plane, finds a bird flying at a distance of 200 m from him at an elevation of  $30^\circ$ . Deepak standing on the roof of a 50 m high building, finds the angle of elevation of the same bird to be  $45^\circ$ . Amit and Deepak are on opposite sides of the bird. Find the distance of the bird from Deepak. (2019)

51. Two poles of equal heights are standing opposite each other on either side of the road, which is 80 m wide. From a point between them on the road, the angles of elevation of the top of the poles are  $60^\circ$  and  $30^\circ$  respectively. Find the height of the poles and the distances of the point from the poles. (NCERT, Delhi 2019)

OR



Two poles of equal heights are standing opposite to each other on either side of the road which is 80 m wide. From a point P between them on the road, the angle of elevation of the top of a pole is  $60^\circ$  and the angle of depression from the top of another pole at point P is  $30^\circ$ . Find the heights of the poles and the distances of the point P from the poles. (Foreign 2015)

52. A boy standing on a horizontal plane finds a bird flying at a distance of 100 m from him at an elevation of  $30^\circ$ . A girl standing on the roof of a 20 m high building, finds the elevation of the same bird to be  $45^\circ$ . The boy and the girl are on the opposite sides of the bird. Find the distance of the bird from the girl. (Given  $\sqrt{2}=1.414$ ) (A/ 2019)

53. The angle of elevation of an aeroplane from a point A on the ground is  $60^\circ$ . After a flight of 30 seconds, the angle of elevation changes to  $30^\circ$ . If the plane is flying at a constant height of  $3600\sqrt{3}$  metres, find the speed of the aeroplane. (AI 2019)

54. As observed from the top of a 100 m high light house from the sea-level, the angles of depression of two ships are  $30^\circ$  and  $45^\circ$ . If one ship is exactly behind the other on the same side of the light house, find the distance between the two ships. [Use  $\sqrt{3} = 1.732$ ] (2018)

55. The angle of elevation of a cloud from a point 60 m above the surface of the water of a lake is  $30^\circ$  and the angle of depression of its shadow in water of lake is  $60^\circ$ . Find the height of the cloud from the surface of water. (Delhi 2017)

56. Two points A and B are on the same side of a tower and in the same straight line with its base. The angles of depression of these points from the top of the tower are  $60^\circ$  and  $45^\circ$  respectively. If the height of the tower is 15 m, then find the distance between these points. (Delhi 2017)

57. An aeroplane is flying at a height of 300 m above the ground. Flying at this height, the angles of depression from the aeroplane of two points on both banks of a river in opposite directions are  $45^\circ$  and  $60^\circ$  respectively. Find the width of the river. [Use  $\sqrt{3}=1.732$ ] (AI 2017)

58. A bird is sitting on the top of a 80 m high tree. From a point on the ground, the angle of elevation of the bird is  $45^\circ$ . The bird flies away horizontally in such a way that it remained at a constant height from the ground. After 2



seconds, the angle of elevation of the bird from the same point is  $30^\circ$ . Find the speed of flying of the bird. (Take  $\sqrt{3}=1.732$ ) (Delhi 2016)

59. The angles of elevation of the top of a tower from two points at a distance of 4 m and 9 m from the base of the tower and in the same straight line with it are  $60^\circ$  and  $30^\circ$  respectively. Find the height of the tower. (Delhi 2016)

60. As observed from the top of light house, 100 m high above sea level, the angles of depression of a ship, sailing directly towards it, changes from  $30^\circ$  to  $60^\circ$ . Find the distance travelled by the ship during the period of observation. (Use  $\sqrt{3}=1.73$ ) (AI 2016)

61. From a point on the ground, the angle of elevation of the top of a tower is observed to be  $60^\circ$ . From a point 40 m vertically above the first point of observation, the angle of elevation of the top of the tower is  $30^\circ$ . Find the height of the tower and its horizontal distance from the point of observation. (AI 2016)

62. A vertical tower stands on a horizontal plane and surmounted by a flagstaff of height 5 m. From a point on the ground the angles of elevation of the top and bottom of the flagstaff are  $60^\circ$  and  $30^\circ$  respectively. Find the height of the tower and the distance of the point from the tower. (Take  $\sqrt{3}=1.732$ ) (Foreign 2016)

OR

From a point P on the ground the angle of elevation of the top of a tower is  $30^\circ$  and that of the top of a flag staff fixed on the top of the tower, is  $60^\circ$ . If the length of the flag staff is 5 m, find the height of the tower. (Delhi 2015)

63. At a point A, 20 metres above the level of water in a lake, the angle of elevation of a cloud is  $30^\circ$ . The angle of depression of the reflection of the cloud in the lake, at A is  $60^\circ$ . Find the distance of the cloud from A. (AI 2015)

64. The angles of elevation and depression of the top and the bottom of a tower from the top of a building, 60 m high, are  $30^\circ$  and  $60^\circ$  respectively. Find the difference between the heights of the building and the tower and the distance between them. (Delhi 2014)

65. The angle of elevation of the top of a tower at a distance of 120 m from a point A on the ground is  $45^\circ$ . If the angle of elevation of the top of a flagstaff





fixed at the top of the tower, at A is  $60^\circ$ , then find the height of the flagstaff.  
[Use  $\sqrt{3}=1.73$ ] (AI 2014)

66. The angle of elevation of the top of a chimney from the foot of a tower is  $60^\circ$  and the angle of depression of the foot of the chimney from the top of the tower is  $30^\circ$ . If the height of the tower is 40 m, find the height of the chimney. According to pollution control norms, the minimum height of a smoke emitting chimney should be 100 m. State if the height of the above mentioned chimney meets the pollution norms. What value is discussed in this question? (Foreign 2014)

## CBSE Sample Questions

### 9.1 Heights and Distances

SA II (3 marks)

1. Two vertical poles of different heights are standing 20 m away from each other on the level ground. The angle of elevation of the top of the first pole from the foot of the second pole is  $60^\circ$  and angle of elevation of the top of the second pole from the foot of the first pole is  $30^\circ$ . Find the difference between the heights of two poles. (Take  $\sqrt{3}=1.73$ ) (Term II, 2021-22)
2. A boy 1.7 m tall is standing on a horizontal ground, 50 m away from a building. The angle of elevation of the top of the building from his eye is  $60^\circ$ . Calculate the height of the building. (Take  $\sqrt{3}=1.73$ ) (Term II, 2021-22)
- 3.

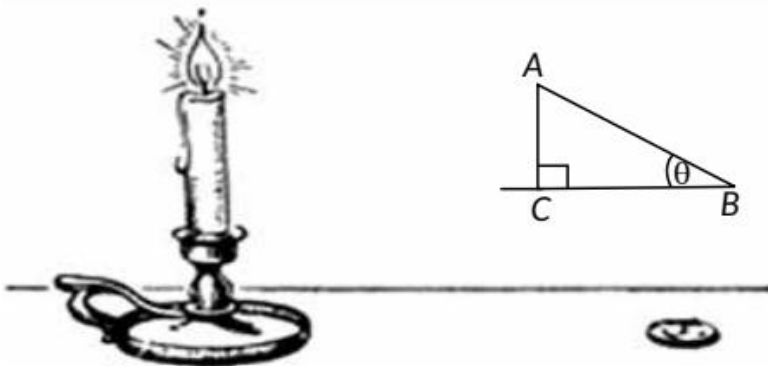

If the angles of elevation of the top of the candle from two coins distant 'a' cm and 'b' cm ( $a > b$ ) from its base and in the same straight line from it are  $30^\circ$  and  $60^\circ$ , then find the height of the candle. (2020-21)

**LA (4/5/6 marks)**

4. Case study: We all have seen the airplanes flying in the sky but might have not thought of how they actually reach the correct destination. Air Traffic Control (ATC) is a service provided by ground-based air traffic controllers who direct aircraft on the ground and through a given section of controlled airspace, and can provide advisory services to aircraft in non-controlled airspace. Actually, all this air traffic is managed and regulated by using various concepts based on coordinate geometry and trigonometry.

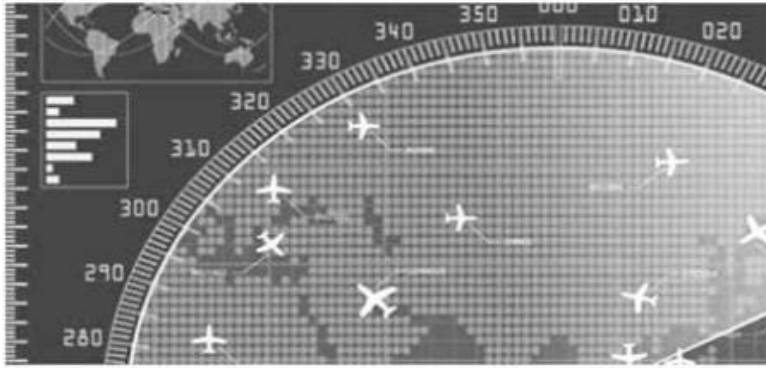

At a given instance, ATC finds that the angle of elevation of an airplane from a point on the ground is  $60^\circ$ . After a flight of 30 seconds, it is observed that the angle of elevation changes to  $30^\circ$ . The height of the plane remains constantly as  $3000\sqrt{3}\text{m}$ . Use the above information to answer the questions that follow:

- (i) Draw a neat labelled figure to show the above situation diagrammatically.
- (ii) What is the distance travelled by the plane in 30 seconds?

**OR**

Keeping the height constant, during the above flight, it was observed that after  $15(\sqrt{3} - 1)$  seconds, the angle of elevation changed to  $45^\circ$ . How much is the distance travelled in that duration?

- (iii) What is the speed of the plane in km/hr? (2022-23)

5. Case study: Trigonometry in the form of triangulation forms the basis of navigation, whether it is by land, sea or air. GPS a radio navigation system helps to locate our position on earth with the help of satellites.

A guard, stationed at the top of a 240 m tower, observed an unidentified boat coming towards it. A clinometer or inclinometer is an instrument used for measuring angles or slopes(tilt). The guard used the clinometer to measure the angle of depression of the boat coming towards the lighthouse and found it



to be  $30^\circ$ .



(Lighthouse of Mumbai Harbour. Picture credits - Times of India Travel)

(i) Make a labelled figure on the basis of the given information and calculate the distance of the boat from the foot of the observation tower.

(ii) After 10 minutes, the guard observed that the boat was approaching the tower and its distance from tower is reduced by  $240(\sqrt{3} - 1)$  m. He immediately raised the alarm. What was the new angle of depression of the boat from the top of the observation tower? (Term II, 2021-22)

6. The two palm trees are of equal heights and are standing opposite each other on either side of the river, which is 80 m wide. From a point O between them on the river the angles of elevation of the top of the trees are  $60^\circ$  and  $30^\circ$ , respectively. Find the height of the trees and the distances of the point O from the trees. (2020-21)

7. The angles of depression of the top and bottom of a building 50 meters high as observed from the top of a tower are  $30^\circ$  and  $60^\circ$  respectively. Find the height of the tower, and also the horizontal distance between the building and the tower. (2020-21)

## SOLUTIONS

### Previous Years' CBSE Board Questions

1.

(a): Let  $\theta$  be the sun's elevation.

$$\text{Then, } \tan\theta = \frac{BC}{AB}$$

$$\Rightarrow \tan\theta = \frac{6}{2\sqrt{3}} = \sqrt{3}$$

$$\Rightarrow \theta = 60^\circ$$

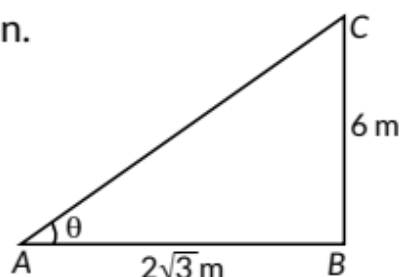

2.

(d): Let MN be the length of the ladder.

In right-angled triangle MNB,

$$\cos 60^\circ = \frac{BN}{MN} \Rightarrow \frac{1}{2} = \frac{2}{MN}$$

$$\Rightarrow MN = 2 \times 2 = 4 \text{ m}$$

Therefore, the length of the ladder is 4 m.

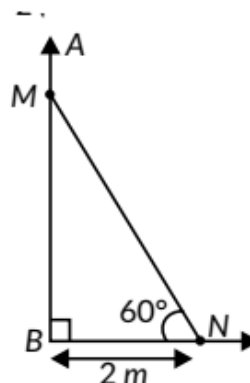

3.

(b): Let, AC =  $x$  m be the distance between tower and car and let AB = 150 m be height of tower.

In  $\triangle ABC$ ,

$$\tan 30^\circ = \frac{150}{x}$$

$$\Rightarrow \frac{1}{\sqrt{3}} = \frac{150}{x} \Rightarrow x = 150\sqrt{3} \text{ m}$$

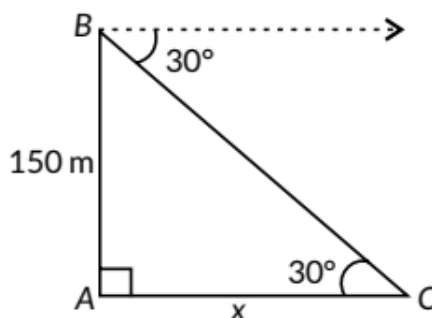

Hence, distance between tower and car =  $150\sqrt{3}$  m.



4.

(b): Let  $BC = h$  be the length of shadow of vertical pole and  $AB = h\sqrt{3}$  be the height of pole.

$$\begin{aligned} \text{In } \triangle ABC, \tan\theta &= \frac{h\sqrt{3}}{h} = \frac{\sqrt{3}}{1} = \tan 60^\circ \\ \Rightarrow \theta &= 60^\circ \end{aligned}$$

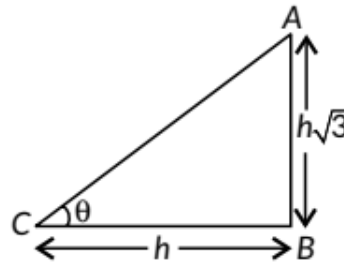

5.

Here,  $AB$  is the tower.

$$\begin{aligned} \text{In } \triangle ABC, \tan 30^\circ &= \frac{AB}{BC} \\ \Rightarrow \frac{1}{\sqrt{3}} &= \frac{AB}{30} \Rightarrow AB = \frac{30}{\sqrt{3}} = 10\sqrt{3} \text{ m} \end{aligned}$$

6.

Let  $AC$  be the length of vertical rod,  $AB$  be the length of its shadow and  $\theta$  be the angle of elevation of the sun.

$$\begin{aligned} \text{In } \triangle ABC, \tan\theta &= \frac{AC}{AB} \\ \Rightarrow \tan\theta &= \frac{1}{\sqrt{3}} \quad (\text{Given}) \\ \Rightarrow \tan\theta &= \tan 30^\circ \Rightarrow \theta = 30^\circ \end{aligned}$$

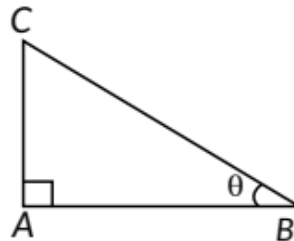

7.

Let  $AC$  be the height of tower,  $AB$  be the length of its shadow and  $\theta$  be the angle of elevation of the sun.

$$\begin{aligned} \text{In } \triangle ABC, \\ \tan\theta &= \frac{AC}{AB} \\ \text{i.e., } \tan\theta &= \frac{\sqrt{3}}{1} \quad (\text{Given}) \\ \Rightarrow \tan\theta &= \tan 60^\circ \Rightarrow \theta = 60^\circ \end{aligned}$$

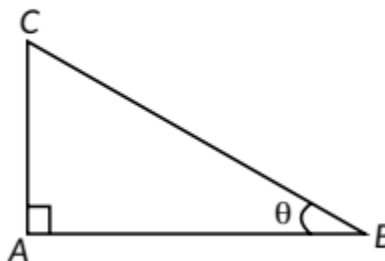

8.

Let angle of elevation of sun be  $\theta$ . Let  $AB$  be the tower and it casts a shadow  $BC$  on the ground.

Now, in  $\triangle ABC$

$$\begin{aligned}\tan\theta &= \frac{AB}{BC} \\ &= \frac{30}{10\sqrt{3}} = \frac{\sqrt{3}}{1} = \tan 60^\circ\end{aligned}$$

$$\Rightarrow \theta = 60^\circ$$

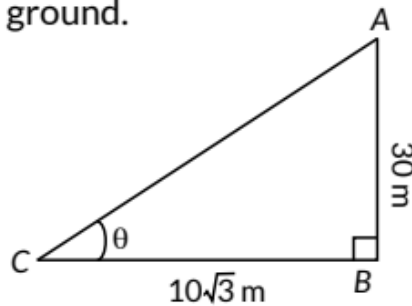

9.

$AB = 6$  m,  $AD = 2.54$  m (given)

$$\therefore BD = AB - AD = 6 - 2.54 = 3.46 \text{ m}$$

Hence, in  $\triangle BDC$ ,  $\frac{BD}{CD} = \sin 60^\circ$

$$\Rightarrow \frac{3.46}{CD} = \frac{\sqrt{3}}{2} \Rightarrow CD = 4 \text{ m}$$

10.

Let  $AC$  be the ladder and  $AB$  is the wall.

In  $\triangle ABC$ ,

$$\cos 60^\circ = \frac{BC}{AC}$$

$$\Rightarrow \frac{1}{2} = \frac{2.5}{AC}$$

$$\therefore AC = 2.5 \times 2 = 5 \text{ m.}$$

$\therefore$  Length of the ladder is 5 m.

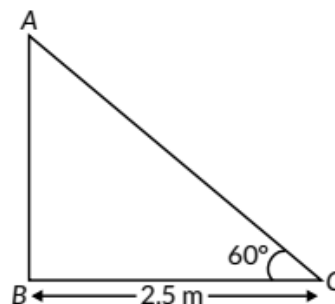

11. Let AB be the observer and CD be the tower of height hm.

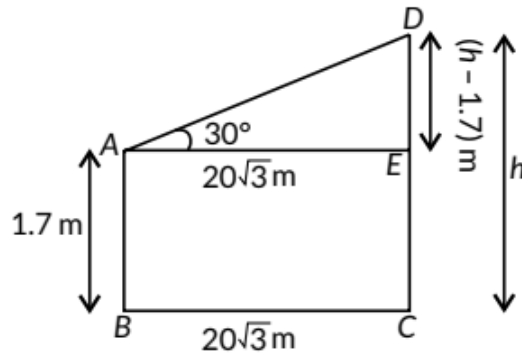

$$\text{In } \triangle AED, \tan 30^\circ = \frac{DE}{AE} = \frac{h-1.7}{20\sqrt{3}}$$

$$\Rightarrow \frac{1}{\sqrt{3}} = \frac{h-1.7}{20\sqrt{3}} \Rightarrow 20 = h - 1.7 \Rightarrow h = 21.7$$

Hence, height of the tower is 21.7 m.

12.

$\therefore$  E is the midpoint of BD.

$\therefore$  BE = ED

Now, in  $\triangle ABE$

$$\tan 30^\circ = \frac{AB}{BE}$$

$$\Rightarrow \frac{1}{\sqrt{3}} = \frac{x}{BE} \Rightarrow x = \frac{BE}{\sqrt{3}}$$

$$\text{And in } \triangle EDC, \tan 60^\circ = \frac{CD}{ED}$$

$$\Rightarrow \sqrt{3} = \frac{y}{ED} \Rightarrow y = \sqrt{3}BE \quad (\because BE = ED)$$

$$\therefore \frac{x}{y} = \frac{BE}{\sqrt{3}} \times \frac{1}{\sqrt{3}BE} = \frac{1}{3}$$

Thus,  $x : y = 1 : 3$ .

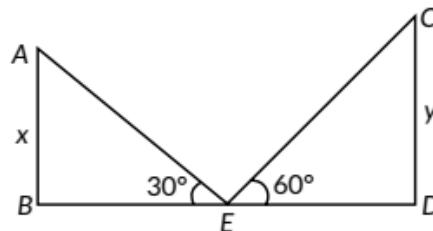

13.

Let Sun's altitude be  $\theta$ .

In  $\triangle ABC$ ,

$$\tan\theta = \frac{AB}{BC} = \frac{20}{20\sqrt{3}} = \frac{1}{\sqrt{3}}$$

$$\Rightarrow \tan\theta = \tan 30^\circ \Rightarrow \theta = 30^\circ$$

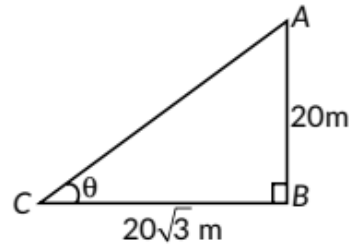

14.

Let  $AB$  is the pole of height  $h$  m and its shadow be  $BC$ .

$$BC = 2\sqrt{3} \text{ m}, \angle ACB = 60^\circ$$

In  $\triangle ABC$ ,

$$\frac{h}{BC} = \tan 60^\circ \Rightarrow \frac{h}{2\sqrt{3}} = \sqrt{3}$$

$$\Rightarrow h = 2 \times 3 = 6$$

$\therefore$  Height of the pole is 6 m.

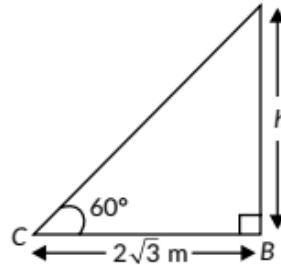

15.

In  $\triangle ACD$ ,  $\angle CAD = 90^\circ$

$$\therefore AD^2 = CD^2 - AC^2 \quad \text{[By Pythagoras theorem]}$$

$$= (3)^2 - (1.5)^2 = 9 - 2.25 = 6.75 \text{ m}^2$$

$$\therefore AD = \sqrt{6.75} = \frac{3\sqrt{3}}{2} \text{ m}$$

$$(i) \quad \tan\theta = \frac{AC}{AD} = \frac{1.5}{\frac{3\sqrt{3}}{2}} \times \frac{2}{1} = \frac{1}{\sqrt{3}}$$

$$(ii) \quad \sec\theta + \operatorname{cosec}\theta = \frac{CD}{AD} + \frac{CD}{AC}$$

$$= 3 \left[ \frac{2}{3\sqrt{3}} + \frac{1}{1.5} \right] = 6 \left[ \frac{1+\sqrt{3}}{3\sqrt{3}} \right] = \frac{2(\sqrt{3}+1)}{\sqrt{3}}$$

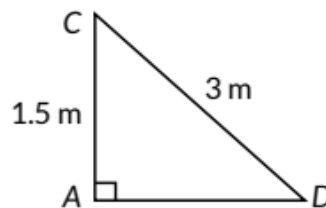

16.

In  $\triangle ABC$                       In  $\triangle ABD$

$$\tan 45 = \frac{p}{b} = \frac{AB}{x}$$

$$\tan 30 = \frac{p}{b} = \frac{AB}{80+x} \Rightarrow \frac{1}{\sqrt{3}} = \frac{AB}{80+x}$$

$$1 = \frac{AB}{x}$$

$$\boxed{AB = x}$$

$$\frac{80+x}{\sqrt{3}} = AB$$

$$80+x = x\sqrt{3}$$

$$80 = \sqrt{3}x - x$$

$$80 = x(\sqrt{3}-1)$$

$$\frac{80}{\sqrt{3}-1} \times \frac{\sqrt{3}+1}{\sqrt{3}+1} = x$$

$$\frac{80(\sqrt{3}+1)}{(\sqrt{3})^2 - 1^2} = x$$

$$\frac{80(\sqrt{3}+1)}{3-1} = x$$

$$\frac{80(\sqrt{3}+1)}{2} = x$$

$$x = 40(\sqrt{3}+1) \text{ m}$$

$$\Rightarrow AB = 40(\sqrt{3}+1) \text{ m or } 109.2 \text{ m}$$

[Topper's Answer, 2022]

17.

Let  $AB$  be the tower of height 50 m and  $CD$  be the building of height  $h$  m.

Now, in  $\triangle ABD$

$$\frac{AB}{BD} = \tan 60^\circ$$

$$\Rightarrow \frac{50}{BD} = \sqrt{3} \Rightarrow BD = \frac{50}{\sqrt{3}} \quad \dots(i)$$

In  $\triangle BDC$ ,

$$\frac{CD}{BD} = \tan 30^\circ \Rightarrow \frac{h}{BD} = \frac{1}{\sqrt{3}} \Rightarrow h = \frac{1}{\sqrt{3}} BD$$

$$\Rightarrow h = \frac{1}{\sqrt{3}} \times \frac{50}{\sqrt{3}} = \frac{50}{3} = 16.67 \quad \text{[Using (i)]}$$

Thus, the height of the building is 16.67 m.

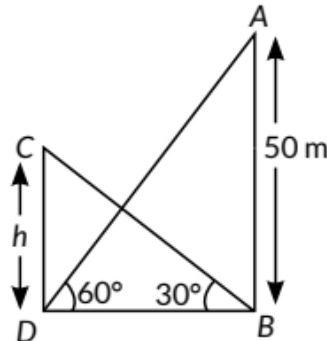

18.

$C$  and  $D$  be the position of two cars.

In  $\triangle ABD$ , we have

$$\frac{AB}{BD} = \tan 45^\circ$$

$$\Rightarrow \frac{50}{BD} = 1$$

$$\Rightarrow BD = 50 \text{ m}$$

In  $\triangle ABC$ , we have

$$\frac{AB}{BC} = \tan 30^\circ \Rightarrow \frac{50}{BC} = \frac{1}{\sqrt{3}} \Rightarrow BC = 50\sqrt{3} \text{ m}$$

$$\begin{aligned} \therefore \text{Distance between two cars} &= CD = CB + BD \\ &= 50\sqrt{3} + 50 \\ &= 50(\sqrt{3} + 1) \text{ m} \end{aligned}$$

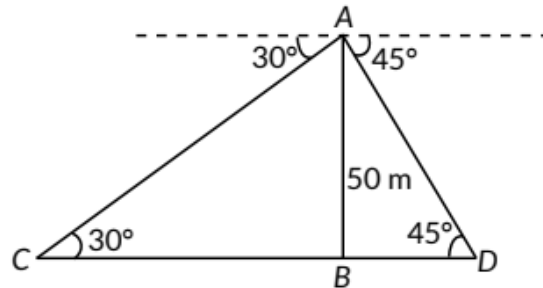



19.

Let A and C be the position of two aeroplanes. Let distance between the two aeroplanes be x m.

In  $\triangle CBD$ , we have

$$\frac{BC}{BD} = \tan 30^\circ$$

$$\frac{3125}{BD} = \frac{1}{\sqrt{3}} \Rightarrow BD = 3125\sqrt{3} \text{ m}$$

In  $\triangle ABD$ , we have

$$\frac{AB}{BD} = \tan 60^\circ$$

$$\frac{x+3125}{BD} = \sqrt{3} \Rightarrow \frac{x+3125}{3125\sqrt{3}} = \sqrt{3} \Rightarrow x+3125 = 3125 \times 3$$

$$\Rightarrow x + 3125 = 9375 \Rightarrow x = 6250$$

$\therefore$  The distance between two planes at that instant is 6250 m.

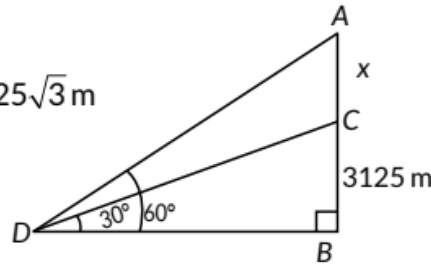

20. Let AB be the tower of height h m and let shadow of tower when sun's altitude is  $60^\circ$  is x i.e. BC = x

In  $\triangle ABC$ , we have

$$\frac{AB}{BC} = \tan 60^\circ \Rightarrow \frac{h}{x} = \sqrt{3}$$

$$\Rightarrow x = \frac{h}{\sqrt{3}} \quad \dots(i)$$

In  $\triangle ABD$ , we have

$$\frac{AB}{BD} = \tan 30^\circ \Rightarrow \frac{h}{x+40} = \frac{1}{\sqrt{3}}$$

$$\Rightarrow x+40 = \sqrt{3}h$$

$$\Rightarrow \frac{h}{\sqrt{3}} + 40 = \sqrt{3}h \quad [\text{From (i)}]$$

$$\Rightarrow \frac{h+40\sqrt{3}}{\sqrt{3}} = \sqrt{3}h \Rightarrow h+40\sqrt{3} = 3h$$

$$\Rightarrow 2h = 40\sqrt{3} \Rightarrow h = 20\sqrt{3}$$

Thus, the height of the tower is  $20\sqrt{3}$  m.

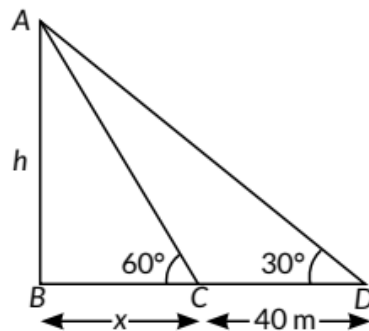

21. Let length of the wire be  $BD$  and the distance between the two poles be  $BE$  i.e.,  $AC = xm$

Here, height of the larger pole,  $CD = 28\text{ m}$

Height of smaller pole,  $AB = 20\text{ m}$

$DE = CD - CE \Rightarrow DE = 28 - 20 = 8\text{ m}$

Now, in  $\triangle BDE$ ,  $\sin 30^\circ = \frac{DE}{BD}$

$$\Rightarrow \frac{1}{2} = \frac{8}{BD}$$

$$\Rightarrow BD = 16\text{ m}$$

$\therefore$  Length of the wire =  $16\text{ m}$

In  $\triangle BDE$ ,  $\cos 30^\circ = \frac{BE}{BD}$

$$\Rightarrow \frac{\sqrt{3}}{2} = \frac{x}{16} \Rightarrow x = \frac{16\sqrt{3}}{2} = 8\sqrt{3} = 8 \times 1.73 = 13.84$$

$\therefore$  The distance between the two poles,  $BE$  is  $13.84\text{ m}$ .

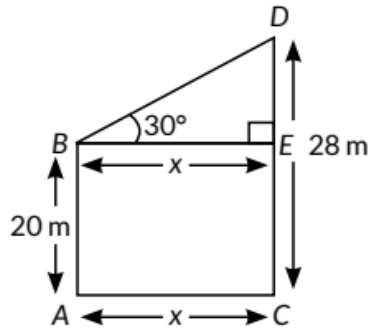

22. Given,  $AB = 75\text{ m}$  be the cliff and  $C, D$  be the positions of two men.

Now, in  $\triangle ABD$ ,

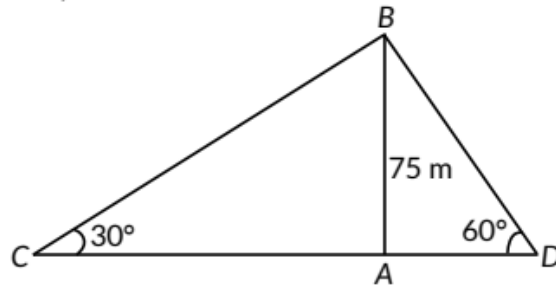

$$\tan 60^\circ = \frac{AB}{AD} \Rightarrow \sqrt{3} = \frac{75}{AD}$$

$$\Rightarrow AD = \frac{75}{\sqrt{3}}\text{ m} = 25\sqrt{3}\text{ m}$$

$$\text{In } \triangle ABC, \tan 30^\circ = \frac{AB}{AC} \Rightarrow \frac{1}{\sqrt{3}} = \frac{75}{AC}$$

$$\Rightarrow AC = 75\sqrt{3}\text{ m}$$

$\therefore$  Distance between the two men =  $AC + AD$

$$= 75\sqrt{3} + 25\sqrt{3} = 100\sqrt{3} = 100 \times 1.73 = 173\text{ m}$$

23. We have, B and D represents points on the bank on opposite sides of the river. Therefore, BD is the width of the river. Let A be a point on the bridge at a height of 8 m.

$$\text{In } \triangle ABC, \tan 45^\circ = \frac{AC}{BC}$$

$$\Rightarrow 1 = \frac{8}{BC}$$

$$\Rightarrow BC = 8 \text{ m}$$

$$\text{In } \triangle ACD, \tan 30^\circ = \frac{AC}{CD}$$

$$\Rightarrow \frac{1}{\sqrt{3}} = \frac{8}{CD} \Rightarrow CD = 8\sqrt{3} \text{ m}$$

$$\therefore \text{Width of the river, } BD = BC + CD$$

$$\Rightarrow BD = 8 + 8\sqrt{3} = 8(1 + \sqrt{3})$$

$$= 8(1 + 1.73) = 8 \times 2.73 = 21.84 \text{ m}$$

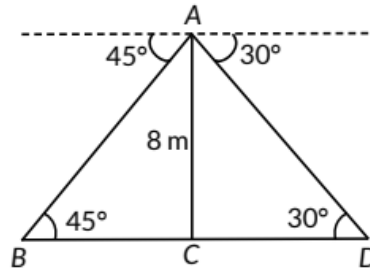

24.

Let AB be the cliff.

$$\text{In } \triangle ACB, \tan 45^\circ = \frac{AB}{BC} \Rightarrow 1 = \frac{150}{BC} \Rightarrow BC = 150 \text{ m}$$

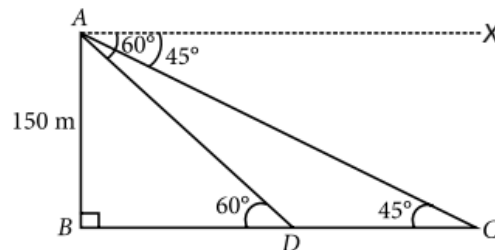

$$\text{In } \triangle ABD, \tan 60^\circ = \frac{AB}{BD}$$

$$\Rightarrow \sqrt{3} = \frac{150}{BD} \Rightarrow BD = \frac{150}{\sqrt{3}} = 50\sqrt{3} \text{ m}$$

$$\text{Distance, } CD = BC - BD = 150 - 50\sqrt{3}$$

$$= 150 - 86.6 = 63.4 \text{ m}$$

Time taken to cover 63.4 m distance

$$= 2 \text{ minutes} = \frac{2}{60} \text{ hour}$$

$$\therefore \text{Speed of the boat} = \frac{63.4}{2} \times 60 = 1902 \text{ m/h}$$



25. Let AB be the building and CD be the tower.

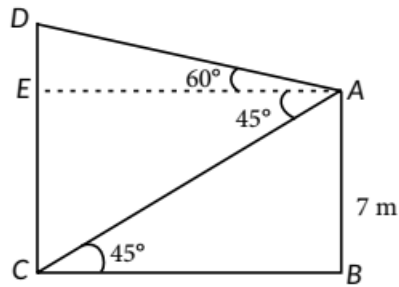

In  $\triangle ABC$ ,

$$\tan 45^\circ = \frac{AB}{BC} = \frac{7}{BC} \Rightarrow 1 = \frac{7}{BC} \Rightarrow BC = 7 \text{ m}$$

$$\text{In } \triangle ADE, \tan 60^\circ = \frac{DE}{AE} = \frac{DE}{BC} \quad (\because AE = BC)$$

$$\Rightarrow \sqrt{3} = \frac{DE}{7} \Rightarrow DE = 7\sqrt{3} \text{ m}$$

Thus, height of the tower =  $CD = CE + DE$

$$= AB + DE = 7 + 7\sqrt{3} = 7(1 + \sqrt{3}) \text{ m}$$

26.

Let  $x$  be distance of hill from man and  $h + 10$  be height of hill.

In right triangle  $ACB$ ,

$$\tan 60^\circ = \frac{h}{BC}$$

$$\Rightarrow \sqrt{3} = \frac{h}{x}$$

$$\Rightarrow x = \frac{h}{\sqrt{3}} \quad \dots(i)$$

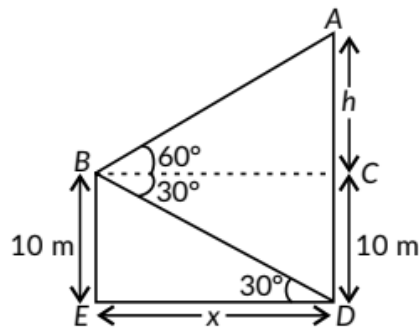

In right triangle  $BCD$

$$\tan 30^\circ = \frac{CD}{BC} = \frac{10}{x} \Rightarrow \frac{1}{\sqrt{3}} = \frac{10}{x} \Rightarrow x = 10\sqrt{3} \quad \dots(ii)$$

From (i) and (ii),

$$\frac{h}{\sqrt{3}} = 10\sqrt{3} \Rightarrow h = 30 \text{ m}$$

$$\therefore \text{Height of hill} = h + 10 = 30 + 10 = 40 \text{ m}$$

$$\text{Distance of ship from hill} = x = 10\sqrt{3} \text{ m} = 17.32 \text{ m}$$

27. Let the height of tower,  $AE = H\text{m}$

The horizontal distance between tower and building =  $x\text{m}$

In  $\triangle ABC$ ,

$$\frac{H-50}{x} = \tan 45^\circ \Rightarrow x = H - 50 \quad \dots(i)$$

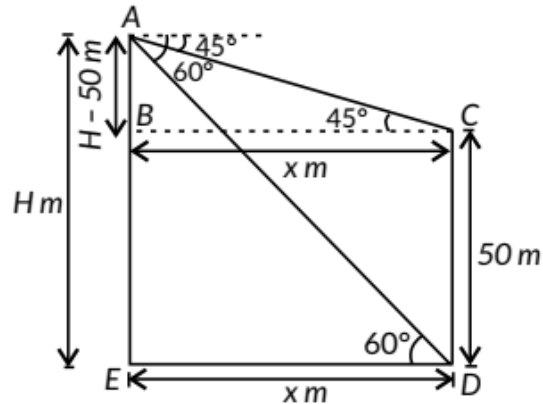

In  $\triangle AED$ ,  $\frac{H}{x} = \tan 60^\circ \Rightarrow x = \frac{H}{\sqrt{3}} \quad \dots(ii)$

From (i) and (ii),  $H - 50 = \frac{H}{\sqrt{3}} \Rightarrow H - \frac{H}{\sqrt{3}} = 50$

$$\Rightarrow H = \frac{50\sqrt{3}}{(\sqrt{3}-1)} = \frac{50(1.73)}{0.73} = 118.49$$

$\therefore$  Height of tower = 118.49 m

$$\begin{aligned} \text{Distance between tower and building} &= \frac{118.49}{\sqrt{3}} \\ &= \frac{118.49}{1.73} = 68.49 \text{ m} \end{aligned}$$

28. Let AB be the tower of height  $h$  m and AD be the flagstaff and C be the required point on the ground at the distance of  $x$  m from the tower.

$$\therefore AD = 7 \text{ m}$$

$$\text{In } \triangle BCD, \tan 60^\circ = \frac{BD}{BC} = \frac{h+7}{x}$$

$$\Rightarrow \sqrt{3}x = h+7 \Rightarrow x = \frac{h+7}{\sqrt{3}} \quad \dots(i)$$

$$\text{In } \triangle ABC, \tan 45^\circ = \frac{AB}{BC} = \frac{h}{x}$$

$$\Rightarrow x = h$$

$$\Rightarrow \frac{h+7}{\sqrt{3}} = h \quad [\text{Using (i)}]$$

$$\Rightarrow \sqrt{3}h = h+7$$

$$\Rightarrow (\sqrt{3}-1)h = 7$$

$$\Rightarrow h = \frac{7}{\sqrt{3}-1} = \frac{7}{0.73} = 9.58 \approx 9.6$$

Hence, height of tower is 9.6 m.

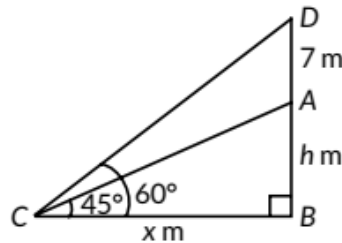

29. Let one aeroplane be at A and second be at D such that vertical distance between two planes is  $h$  m.

$$\text{In } \triangle ABC, \tan 60^\circ = \frac{AC}{BC}$$

$$\Rightarrow \sqrt{3} = \frac{4000}{x} \Rightarrow x = \frac{4000}{\sqrt{3}} \quad \dots(i)$$

$$\text{In } \triangle DBC, \tan 45^\circ = \frac{DC}{BC}$$

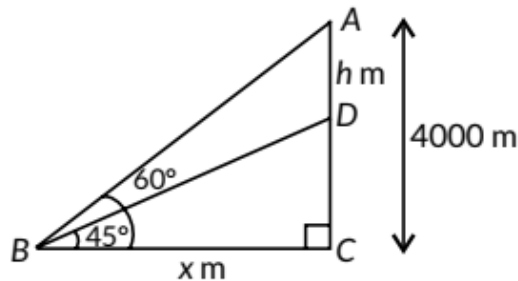

$$\Rightarrow 1 = \frac{4000-h}{x} \Rightarrow x = 4000-h$$

$$\Rightarrow \frac{4000}{\sqrt{3}} = 4000-h \quad \text{[Using (i)]}$$

$$\Rightarrow h = 4000 - \frac{4000}{\sqrt{3}} = 4000 - \frac{4000\sqrt{3}}{3}$$

$$= \frac{12000-6920}{3} = \frac{5080}{3} = 1693.33$$

Hence, vertical distance between the aeroplanes at that instant was 1693.33 m.

30. Let AB be the tower of height 30 m and DC is the building of height h m.

$$\text{In } \triangle ABC, \tan 45^\circ = \frac{AB}{BC}$$

$$\Rightarrow 1 = \frac{30}{BC} \Rightarrow BC = 30 \text{ m}$$

$$\text{In } \triangle BDC, \tan 30^\circ = \frac{CD}{BC}$$

$$\Rightarrow \frac{1}{\sqrt{3}} = \frac{h}{30} \Rightarrow \sqrt{3}h = 30$$

$$\Rightarrow h = \frac{30}{\sqrt{3}} = 10\sqrt{3} = 17.32$$

Thus, height of building is 17.32 m.

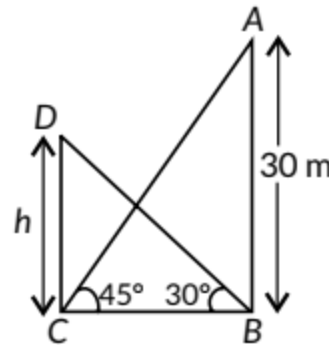

31. Let B be the initial position and D be the final position after 15 seconds of the flight as observed from a point A on the ground.

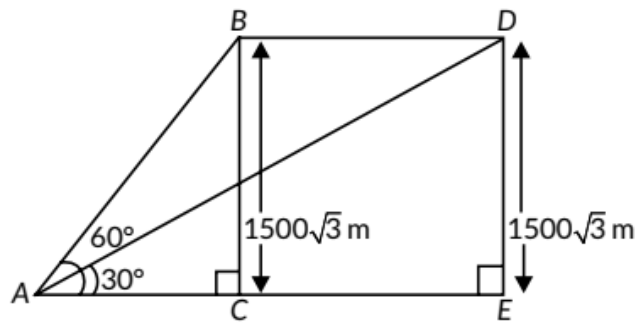

In  $\triangle ABC$ ,

$$\tan 60^\circ = \frac{BC}{AC} \Rightarrow \sqrt{3} = \frac{1500\sqrt{3}}{AC}$$

$$\Rightarrow AC = 1500 \text{ m}$$

$$\text{In } \triangle ADE, \tan 30^\circ = \frac{DE}{AE} \Rightarrow \frac{1}{\sqrt{3}} = \frac{1500\sqrt{3}}{AE}$$

$$\Rightarrow AE = 4500 \text{ m}$$

Distance travelled in 15 seconds is  $BD$   
 $= CE = AE - AC = 4500 - 1500 = 3000 \text{ m} = 3 \text{ km}$

$$\text{Time taken} = 15 \text{ s} = \frac{15}{60 \times 60} \text{ hr}$$

$$\text{Speed of plane} = \frac{\text{Distance}}{\text{Time}} = \frac{3 \times 60 \times 60}{15} = 720 \text{ km/hr.}$$



32. Let AB be the height of tower and CD = h be the height of the pole.

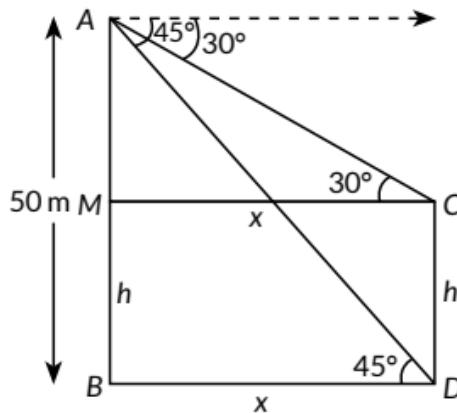

Let,  $BD = x$  be the distance of the tower from the pole.

$$AM = AB - BM = (50 - h)m$$

$$(i) \text{ In } \triangle ABD, \tan 45^\circ = \frac{AB}{BD} = \frac{50}{x}$$

$$\Rightarrow 1 = \frac{50}{x} \Rightarrow x = 50 \quad \dots(i)$$

$\therefore$  The pole is 50 m away from the bottom of the tower.

$$(ii) \text{ In } \triangle AMC, \tan 30^\circ = \frac{AM}{MC} = \frac{50-h}{x}$$

$$\Rightarrow \frac{1}{\sqrt{3}} = \frac{50-h}{50} \quad (\text{From (i)})$$

$$\Rightarrow h = \frac{50\sqrt{3}-50}{\sqrt{3}} = \frac{36.6}{1.732} = 21.13 \text{ m}$$

$\therefore$  Height of the pole is 21.13 m.

33. Let 'd' m be the distance between the two ships. Suppose the distance of one of the ships from the light house is x m, then the distance of the other ship from the light house is (d - x) m.

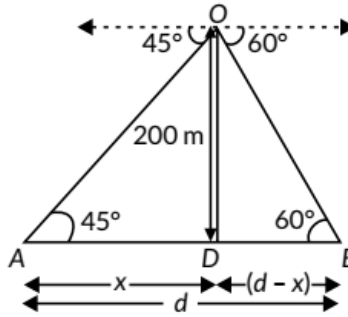

In right-angled  $\triangle ADO$ , we have

$$\tan 45^\circ = \frac{OD}{AD} \Rightarrow 1 = \frac{200}{x} \Rightarrow x = 200 \quad \dots(i)$$

In right-angled  $\triangle BDO$ , we have

$$\begin{aligned} \tan 60^\circ &= \frac{OD}{BD} \Rightarrow \sqrt{3} = \frac{200}{d-x} \\ \Rightarrow (d-x)\sqrt{3} &= 200 \Rightarrow \sqrt{3}d - x\sqrt{3} = 200 \\ \Rightarrow \sqrt{3}d - 200\sqrt{3} &= 200 \quad (\because x = 200) && \text{(Using (i))} \\ \Rightarrow \sqrt{3}d &= 200(\sqrt{3} + 1) \\ \Rightarrow d &= \frac{200(\sqrt{3} + 1)}{\sqrt{3}} = \frac{200 \times 2.73}{1.73} \approx 315.61 \end{aligned}$$

Thus, the distance between two ships is approximately 315.61 m.

34.

Let  $A$  be the initial position of the plane and  $B$  is the position after 30 seconds.

Let  $ED$  be  $x$  m  
and  $DC = y$  m

$$BC = AD = 3000\sqrt{3} \text{ m}$$

$$\text{In } \triangle AED, \tan 60^\circ = \frac{AD}{ED}$$

$$\Rightarrow \sqrt{3} = \frac{3000\sqrt{3}}{x} \Rightarrow x = 3000$$

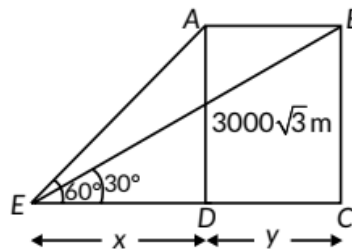

Now, in  $\triangle BEC$ ,

$$\tan 30^\circ = \frac{BC}{EC} = \frac{BC}{ED + DC} = \frac{BC}{x + y} \Rightarrow \frac{1}{\sqrt{3}} = \frac{3000\sqrt{3}}{3000 + y}$$

$$\begin{aligned} \Rightarrow 3000 + y &= 3000 \times 3 = 9000 \\ y &= 9000 - 3000 = 6000 \end{aligned}$$

$$\begin{aligned} \text{Speed} &= \frac{\text{Distance}}{\text{Time}} = \frac{AB}{\text{Time}} = \frac{6000}{30} \quad (\because AB = y = 6000 \text{ m}) \\ &= 200 \text{ m/s.} \end{aligned}$$

35.

Let  $AB$  be the building and  $DC$  be the tower of height  $h$  m.

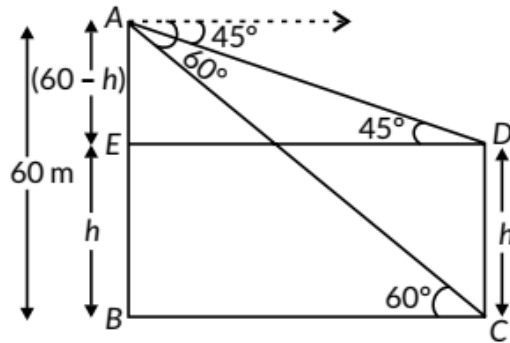

$$\text{In } \triangle ABC, \tan 60^\circ = \frac{AB}{BC} \Rightarrow \sqrt{3} = \frac{60}{BC} \Rightarrow BC = \frac{60}{\sqrt{3}} \text{ m}$$

$$\text{In } \triangle AED, \tan 45^\circ = \frac{AE}{ED} \Rightarrow 1 = \frac{(60-h)}{\frac{60}{\sqrt{3}}} \quad (\because BC = ED)$$

$$\Rightarrow \frac{60}{\sqrt{3}} = 60 - h \Rightarrow h = 60 - \frac{60}{\sqrt{3}} = 60 \frac{(\sqrt{3}-1)}{\sqrt{3}}$$

$$\Rightarrow h = 60 \left( \frac{1.73-1}{1.73} \right) = 60 \left( \frac{0.73}{1.73} \right) = 25.3 \text{ km} = 25.32$$

$\therefore$  Height of tower = 25.32 m

36.

Let  $AB$  be the light house and two ships  $C$  and  $D$  are 100 m apart.

Let  $BC = x$  then,  $BD = 100 - x$

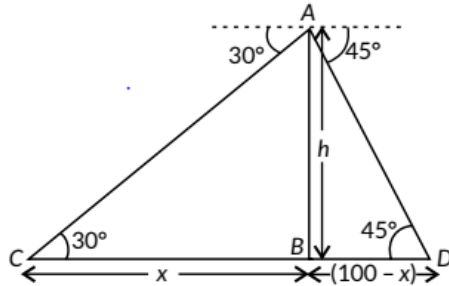

$$\text{In } \triangle ABC, \tan 30^\circ = \frac{h}{x} \Rightarrow \frac{1}{\sqrt{3}} = \frac{h}{x}$$

$$\Rightarrow h = \frac{x}{\sqrt{3}} \quad \dots(i)$$

$$\text{In } \triangle ABD, \tan 45^\circ = \frac{h}{100-x} \Rightarrow 1 = \frac{h}{100-x} \Rightarrow 100 - x = h$$

$$\Rightarrow 100 - x = \frac{x}{\sqrt{3}} \quad (\text{From (i)})$$

$$\Rightarrow 100\sqrt{3} = x(\sqrt{3} + 1) \Rightarrow x = \frac{100(\sqrt{3})}{\sqrt{3} + 1}$$

$$\therefore h = \frac{100}{\sqrt{3} + 1} \times \frac{\sqrt{3} - 1}{\sqrt{3} - 1} = \frac{100 \times 0.732}{2} = \frac{73.2}{2} = 36.6 \text{ m}$$

37. Let the tower be  $CD$  and points  $A$  and  $B$  be the positions of two cars on the highway. Height of the tower  $CD = 75$  m.

In  $\triangle DCB$ ,

$$\tan 60^\circ = \frac{DC}{BC}$$

$$\Rightarrow \sqrt{3} = \frac{75}{BC} \Rightarrow BC = \frac{75}{\sqrt{3}}$$

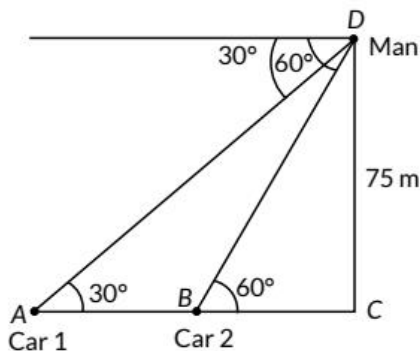

Now, in  $\triangle ACD$ ,

$$\tan 30^\circ = \frac{DC}{AC} \Rightarrow \frac{1}{\sqrt{3}} = \frac{75}{AC}$$

$$\Rightarrow AC = 75\sqrt{3}$$

Now, the distance between two cars is

$$AB = AC - BC$$

$$= 75\sqrt{3} - \frac{75}{\sqrt{3}} = \frac{150}{\sqrt{3}} = 86.71 \text{ m}$$

38.

Let  $AE$  be the building with height 7 m and  $BD$  be the tower with height  $h$  m.

In  $\triangle ABC$ ,

$$\tan 60^\circ = \frac{BC}{AC}$$

$$\Rightarrow \sqrt{3} = \frac{BC}{AC}$$

$$\Rightarrow BC = AC\sqrt{3} \quad \dots(i)$$

In triangle  $ACD$ ,  $\tan 30^\circ = \frac{CD}{AC}$

$$\Rightarrow \frac{1}{\sqrt{3}} = \frac{7}{AC} \Rightarrow AC = 7\sqrt{3} \quad \dots(ii)$$

From (i) and (ii), we get

$$BC = 7\sqrt{3} \times \sqrt{3} = 21 \text{ m}$$

$$\therefore \text{Height of the tower} = BC + CD = 21 \text{ m} + 7 \text{ m} = 28 \text{ m}$$

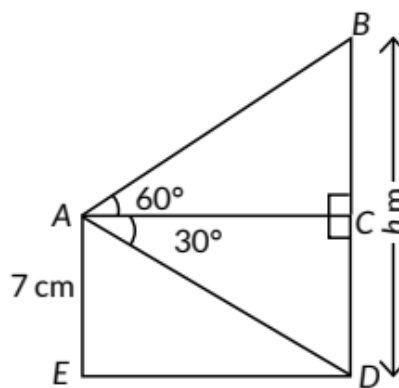

39.

Let  $AE = CD = y$  be the length of the ladder and  $h$  be the final height of the top of the ladder from the ground.

$$\text{In } \triangle ABE, \tan 45^\circ = \frac{AB}{BE}$$

$$\Rightarrow 1 = \frac{AB}{x} = \frac{3+h}{x}$$

$$\Rightarrow x = (3+h)m$$

$$\text{In } \triangle DBC, \tan 30^\circ = \frac{DB}{BC}$$

$$\Rightarrow \frac{1}{\sqrt{3}} = \frac{h}{4+x}$$

$$\Rightarrow \frac{1}{\sqrt{3}} = \frac{h}{4+3+h}$$

$$\Rightarrow 7+h = \sqrt{3}h$$

$$\Rightarrow \sqrt{3}h - h = 7$$

$$\Rightarrow h(\sqrt{3}-1) = 7$$

$$\Rightarrow h = \frac{7}{\sqrt{3}-1} = \frac{7}{1.732-1} = 9.56m$$

$$\text{Now, } \sin 45^\circ = \frac{AB}{AE}$$

$$\Rightarrow \frac{1}{\sqrt{2}} = \frac{3+h}{y}$$

$$\Rightarrow y = (3+h)\sqrt{2} = (3+9.56)1.414 = 17.76m$$

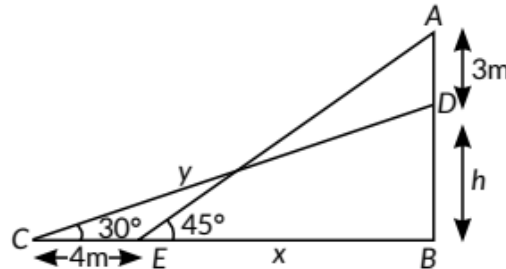

$$(\because x = (3+h)m)$$

40.

$\text{In } \triangle QOY$   
 $\tan 45 = \frac{P}{B} = \frac{QO}{OY} = \frac{x}{OY}$   
 $1 = \frac{x}{OY}$   
 $OY = x \Rightarrow P_x = x$

$\text{In } \triangle POX$   
 $\tan 60 = \frac{P}{B} = \frac{PO}{PX} = \frac{40+x}{x}$   
 $\sqrt{3} = \frac{40+x}{x}$   
 $\sqrt{3}x = 40+x$   
 $\sqrt{3}x - x = 40$   
 $x(\sqrt{3}-1) = 40$   
 $x = \frac{40}{(\sqrt{3}-1)} \times \frac{\sqrt{3}+1}{\sqrt{3}+1} = \frac{40(\sqrt{3}+1)}{(\sqrt{3})^2-1^2} = \frac{40(\sqrt{3}+1)}{3-1}$   
 $x = \frac{40(\sqrt{3}+1)}{2}$   
 $x = 20(\sqrt{3}+1) \text{ m}$   
 $x = 54.6 \text{ m}$   
 $\Rightarrow P_x = 54.6 \text{ m}$

$PQ = 40+x$   
 $= 40+54.6$   
 $= 94.6 \text{ m}$

[Topper's Answer, 2022]

41.

Let  $h$  be the height of the tower and  $D$  be the initial position of car and let  $DB = a$ ,  $AB = b$

Now, In  $\triangle CAD$ ,

$$\tan 30^\circ = \frac{AC}{AD} = \frac{h}{a+b}$$

$$\Rightarrow h = \frac{a+b}{\sqrt{3}}$$

$$\left[ \because \tan 30^\circ = \frac{1}{\sqrt{3}} \right]$$

...(i)

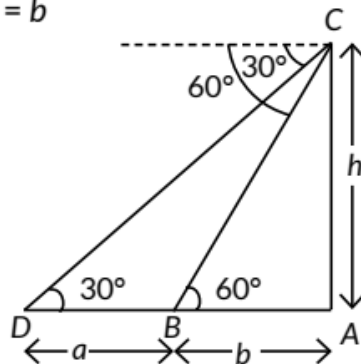

In  $\triangle ABC$ ,  $\tan 60^\circ = \frac{AC}{AB} = \frac{h}{b}$

$$\Rightarrow h = b\sqrt{3}$$

...(ii)

$$\left[ \because \tan 60^\circ = \sqrt{3} \right]$$

Eliminating  $h$ , from (i) and (ii), we have

$$\sqrt{3}b = \frac{a+b}{\sqrt{3}} \Rightarrow 3b = a+b \Rightarrow 2b = a$$

As the car covers distance  $a$  i.e.,  $2b$  in 10 seconds.

So, it will take 5 seconds to reach the foot of the tower.

42. (i): Given,  $AD = 50$  m,  $BE = 60$  m Let the lengths of strings used for kite A be  $AC$  and for kite B be  $BC$ .

Now, in  $\triangle ADC$ ,  $\sin 30^\circ = \frac{AD}{AC}$

$$\Rightarrow \frac{1}{2} = \frac{50}{AC}$$

$$\Rightarrow AC = 100 \text{ m}$$

In  $\triangle BEC$ ,

$$\sin 60^\circ = \frac{BE}{BC}$$

$$\Rightarrow \frac{\sqrt{3}}{2} = \frac{60}{BC} \Rightarrow BC = \frac{120}{\sqrt{3}} = 40\sqrt{3} \text{ m.}$$

Hence,  $AC = 100$  m and  $BC = 40\sqrt{3}$  m

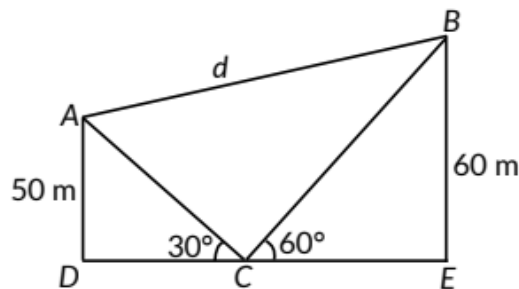



(ii) Since, the distance between these two kites is  $d$ .  
 $\Delta ABC$  is a right angle triangle ( $\angle ZACB = 90^\circ$ )  
 Now, in  $\Delta ABC$ , by using Pythagoras theorem, we have  
 $BA^2 = BC^2 + AC^2$

$$BA^2 = BC^2 + AC^2$$

$$\Rightarrow BA^2 = (40\sqrt{3})^2 + (100)^2 \Rightarrow BA^2 = 4800 + 10000 = 14800$$

$$\Rightarrow BA = \sqrt{14800} = 121.65 \text{ m}$$

Hence, the distance between these two kites is 121.65 m.

43. Let  $AB$  be the tower of height  $h$  m and  $D$  be the initial position of the car and  $C$  be the position of car after 18 minutes.

Let  $CD = x$  and  $BC = y$   
 In  $\Delta ABD$ , we have

$$\frac{AB}{BD} = \tan 30^\circ$$

$$\Rightarrow \frac{h}{y+x} = \frac{1}{\sqrt{3}} \Rightarrow x+y = \sqrt{3}h$$

$$\Rightarrow h = \frac{x+y}{\sqrt{3}} \quad \dots(i)$$

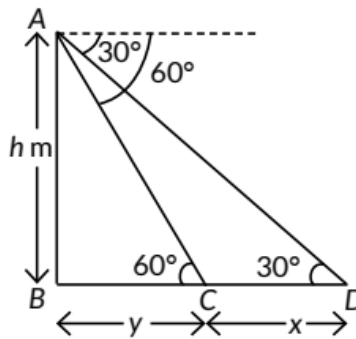

In  $\Delta ABC$ , we have

$$\frac{AB}{BC} = \tan 60^\circ \Rightarrow \frac{h}{y} = \sqrt{3} \Rightarrow h = \sqrt{3}y \quad \dots(ii)$$

On comparing (i) and (ii), we have

$$\frac{x+y}{\sqrt{3}} = \sqrt{3}y \Rightarrow x+y = 3y \Rightarrow x = 2y$$

Distance  $x$  is covered by car in 18 minutes

$\therefore$  Distance  $2y$  is covered by car in 18 minutes [ $\because x = 2y$ ]  
 $\Rightarrow$  Distance  $y$  will be covered by car in 9 minutes.

44. Let  $AB$  be the hill of height  $h$  m and distance of hill from platform i.e.,  $BD = x$  m.

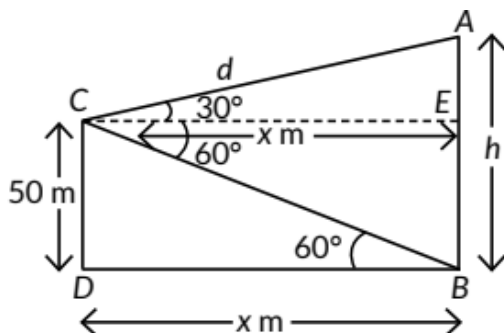

In  $\triangle BDC$ , we have

$$\frac{CD}{BD} = \tan 60^\circ \Rightarrow \frac{50}{x} = \sqrt{3} \Rightarrow x = \frac{50}{\sqrt{3}}$$

Now, in  $\triangle AEC$ , we have

$$\frac{AE}{CE} = \tan 30^\circ \Rightarrow \frac{AB - BE}{CE} = \frac{1}{\sqrt{3}}$$

$$\Rightarrow h - 50 = \frac{1}{\sqrt{3}}x \quad [\because BD = CE = x]$$

$$\Rightarrow h - 50 = \frac{1}{\sqrt{3}} \times \frac{50}{\sqrt{3}} \Rightarrow h - 50 = \frac{50}{3}$$

$$\Rightarrow h = 50 + 16.67 \Rightarrow h = 66.6 \text{ m}$$

Hence, distance of the hill from platform =  $x \text{ m} = \frac{50}{\sqrt{3}} \text{ m}$   
and height of the hill is 66.67 m.

45. Let P be the point of observation. AB is the building of height 20 m and AC is the transmission tower.

$$\text{In } \triangle ABP, \frac{AB}{BP} = \tan 45^\circ$$

$$\Rightarrow \frac{20}{BP} = 1 \Rightarrow BP = 20 \text{ m}$$

$$\text{In } \triangle CBP, \frac{CB}{BP} = \tan 60^\circ$$

$$\Rightarrow \frac{AB + AC}{BP} = \sqrt{3} \Rightarrow \frac{20 + AC}{20} = \sqrt{3}$$

$$\Rightarrow 20 + AC = 20\sqrt{3} \Rightarrow AC = 20\sqrt{3} - 20 = 20(\sqrt{3} - 1)$$

$$= 20(1.73 - 1) = 20 \times 0.73 = 14.6 \text{ m}$$

Thus, the height of the tower is 14.6 m.

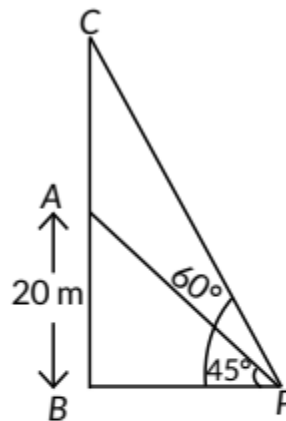

46. In the figure, A represents the point of observation, DC represents the statue and BC represents the pedestal. Now, in right  $\triangle ABC$ , we have

$$\frac{AB}{BC} = \cot 45^\circ = 1$$

$$\Rightarrow \frac{AB}{h} = 1 \Rightarrow AB = h \text{ m}$$

Now in right  $\triangle ABD$ , we have

$$\frac{BD}{AB} = \tan 60^\circ = \sqrt{3}$$

$$\Rightarrow BD = \sqrt{3} \times AB = \sqrt{3} \times h$$

$$\Rightarrow h + 1.6 = \sqrt{3}h$$

$$\Rightarrow h(\sqrt{3} - 1) = 1.6 \Rightarrow h = \frac{1.6}{0.73} = 2.19$$

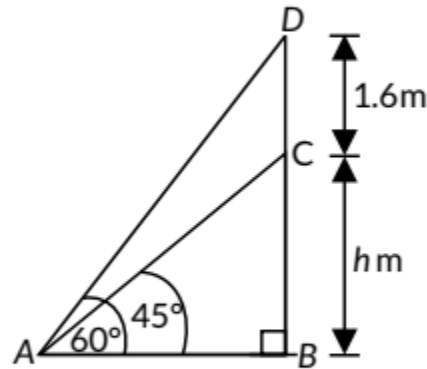

Thus, the height of the pedestal is 2.19 m.

47. Let AB be the tower at height  $h$  m and CD be the building of height 8m and let  $x$  m be the distance between the tower and building.

In  $\triangle ABD$ , we have

$$\frac{AB}{BD} = \tan 45^\circ$$

$$\Rightarrow \frac{h+8}{x} = 1 \Rightarrow h+8 = x \quad \dots(i)$$

In  $\triangle AEC$ , we have

$$\frac{AE}{EC} = \tan 30^\circ \Rightarrow \frac{h}{x} = \frac{1}{\sqrt{3}} \Rightarrow x = \sqrt{3}h \quad \dots(ii)$$

Put  $x = \sqrt{3}h$  in (i), we get

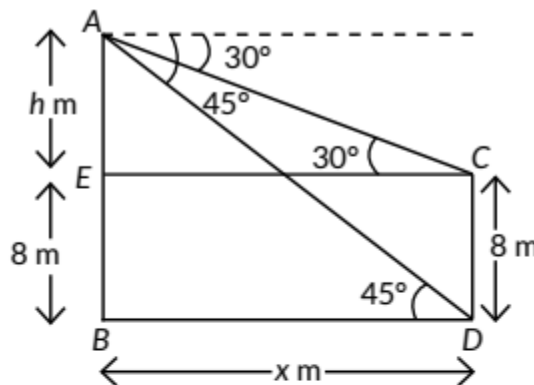

$$h+8=\sqrt{3}h$$

$$\Rightarrow h=\frac{8}{\sqrt{3}-1} \Rightarrow h=\frac{8}{2}(\sqrt{3}+1)=4(\sqrt{3}+1)$$

From (ii), we have

$$x=\sqrt{3}h=\sqrt{3}\times 4(\sqrt{3}+1)=4(3+\sqrt{3})$$

Now, the height of the tower = AB

$$=AE+EB=h+8=4(\sqrt{3}+1)+8=4\sqrt{3}+4+8$$

$$=4\sqrt{3}+12=4(3+\sqrt{3})\text{m}$$

and distance between tower and building =  $x=4(3+\sqrt{3})\text{m}$

48. Let AB be the lighthouse and C and D be the position of two ships.

Now, in  $\triangle ABC$

$$\frac{AB}{BC}=\tan 45^\circ$$

$$\Rightarrow \frac{75}{BC}=1$$

$$\Rightarrow BC=75\text{ m}$$

Now in  $\triangle ABD$ , we have

$$\frac{AB}{BD}=\tan 30^\circ \Rightarrow \frac{AB}{DC+BC}=\frac{1}{\sqrt{3}}$$

$$\Rightarrow \frac{75}{DC+75}=\frac{1}{\sqrt{3}} \Rightarrow DC+75=75\sqrt{3} \Rightarrow DC=75(\sqrt{3}-1)$$

Hence, distance between two ships is  $75(\sqrt{3}-1)\text{m}$ .

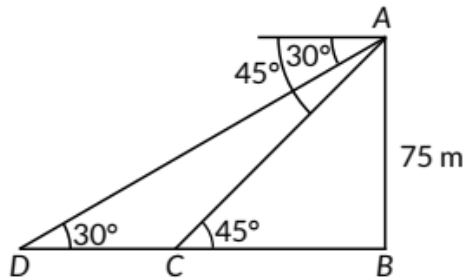

49.

Let  $AB = 100$  m be the height of the light house.

Let the initial distance be  $x$  m and angle is  $60^\circ$ .

In  $\triangle ABC$ ,

$$\tan 60^\circ = \frac{AB}{BC} = \frac{100}{x}$$

$$\Rightarrow \sqrt{3} = \frac{100}{x} \Rightarrow x = \frac{100}{\sqrt{3}}$$

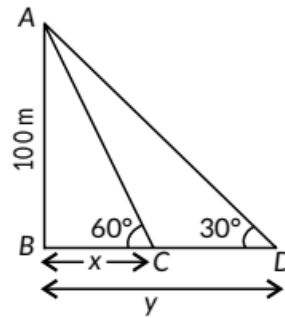

Now, after two minutes, new distance be  $y$  m and angle is  $30^\circ$ .

In  $\triangle ABD$ ,

$$\tan 30^\circ = \frac{AB}{BD} = \frac{100}{y} \Rightarrow \frac{1}{\sqrt{3}} = \frac{100}{y} \Rightarrow y = 100\sqrt{3}$$

$\therefore$  Distance travelled in 2 minutes =  $y - x$

$$= 100\sqrt{3} - \frac{100}{\sqrt{3}} = \frac{300 - 100}{\sqrt{3}} = \frac{200}{\sqrt{3}} = \frac{200}{1.732} = 115.47 \text{ m}$$

$$\text{Speed of boat} = \frac{\text{Distance}}{\text{Time}}$$

$$= \frac{115.47}{2} = 57.74 \text{ metres/minute}$$

50. Here, A be the position of Amit, B be the position of bird and D be the position of Deepak standing on roof of the building CD of height 50 m.

In  $\triangle AMB$ , we have

$$\frac{BM}{AB} = \sin 30^\circ \Rightarrow \frac{h+50}{200} = \frac{1}{2} \Rightarrow h+50=100$$

$$\Rightarrow h = 50 \text{ m}$$

Now, in  $\triangle BLD$

$$\frac{BL}{BD} = \sin 45^\circ \Rightarrow \frac{h}{BD} = \frac{1}{\sqrt{2}} \Rightarrow \frac{50}{BD} = \frac{1}{\sqrt{2}}$$

$$\Rightarrow BD = 50\sqrt{2} \text{ m}$$

Hence, distance of bird from Deepak is  $50\sqrt{2}$  m.

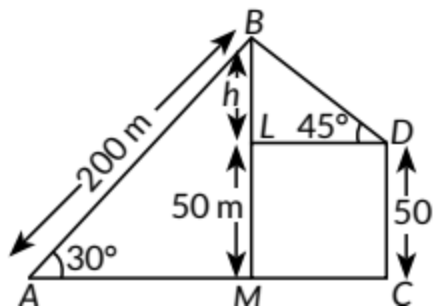

51. Let AB and CD be two poles of height  $h$  m. Let P be a point on road such that  $BP = x$  m so that

$$PD = BD - BP = (80 - x) \text{ m}$$

In  $\triangle ABP$ ,

$$\frac{h}{x} = \tan 60^\circ$$

$$\Rightarrow h = \sqrt{3}x \quad \dots(i)$$

In  $\triangle CDP$ ,

$$\frac{h}{80-x} = \tan 30^\circ \Rightarrow h = \frac{1}{\sqrt{3}}(80-x) \quad \dots(ii)$$

From (i) and (ii), we have

$$\sqrt{3}x = \frac{1}{\sqrt{3}}(80-x) \Rightarrow 3x = 80 - x$$

$$\Rightarrow 4x = 80 \text{ or } x = 20$$

Distance of point P from AB = 20 m

Distance of point P from CD =  $80 - 20 = 60$  m

Height of each pole,  $h = x\sqrt{3} = 20\sqrt{3} = 20 \times 1.732 = 34.64$  m

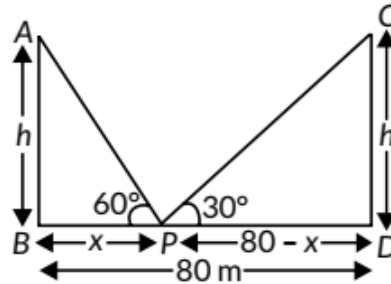

52 Let P be the position of bird, B and G be the position of the boy and the girl respectively.

GN be the building at which the girl is standing.

In  $\triangle PMB$ ,

$$\frac{PM}{BP} = \sin 30^\circ$$

$$\Rightarrow PM = 100 \times \frac{1}{2} = 50 \text{ m}$$

Now,  $PL = PM - LM = 50 - 20 = 30$  m

$$\text{In } \triangle PLG, \frac{PL}{PG} = \sin 45^\circ \Rightarrow \frac{30}{PG} = \frac{1}{\sqrt{2}}$$

$$\Rightarrow PG = 30\sqrt{2} = 30 \times 1.414 = 42.42 \text{ m}$$

Hence, the bird is flying at a distance of 42.42 m from the girl.

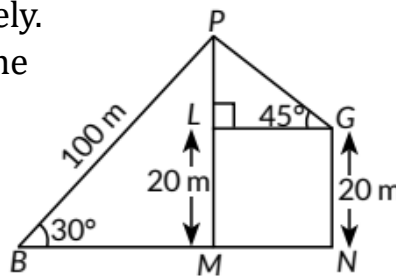

53. Let P and Q be the two positions of the aeroplane. Given, angle of elevation of the aeroplane in two positions P and Q from A is  $60^\circ$  and  $30^\circ$  respectively.

In  $\triangle ABP$ , we have

$$\tan 60^\circ = \frac{BP}{AB}$$

$$\Rightarrow \sqrt{3} = \frac{3600\sqrt{3}}{AB}$$

$$\Rightarrow AB = 3600 \text{ m}$$

In  $\triangle ACQ$ , we have

$$\tan 30^\circ = \frac{CQ}{AC} \Rightarrow \frac{1}{\sqrt{3}} = \frac{3600\sqrt{3}}{AC}$$

$$\Rightarrow AC = 3600 \times 3 = 10800 \text{ m}$$

$$\begin{aligned} \therefore \text{Distance covered by aeroplane} \\ &= PQ = BC = AC - AB = 10800 - 3600 \\ &= 7200 \text{ m} \end{aligned}$$

Thus, aeroplane travels 7200 m in 30 seconds.

$$\text{Hence, speed of aeroplane} = \frac{7200}{30} = 240 \text{ m/sec.}$$

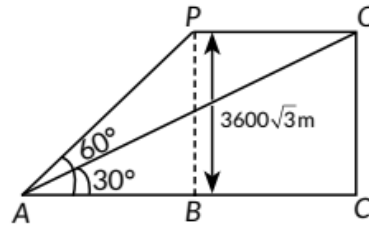

54. In the figure, let AB represent the light house.

..  $AB = 100 \text{ m}$  Let the positions of two ships be C and D such that angle of depression from A are  $45^\circ$  and  $30^\circ$  respectively. Now, in right  $\triangle ABC$ ,

$$\frac{AB}{BC} = \tan 45^\circ$$

$$\Rightarrow \frac{100}{BC} = 1 \Rightarrow BC = 100 \text{ m}$$

Again, in right  $\triangle ABD$ , we have

$$\frac{AB}{BD} = \tan 30^\circ$$

$$\Rightarrow \frac{100}{BD} = \frac{1}{\sqrt{3}} \Rightarrow BD = 100\sqrt{3} \text{ m}$$

The distance between the two ships = CD

$$= BD - BC = 100\sqrt{3} - 100$$

$$= 100(\sqrt{3} - 1) = 100(1.732 - 1)$$

$$= 100 \times 0.732 = 73.2 \text{ m}$$

Thus, the required distance between the ships is 73.2 m.

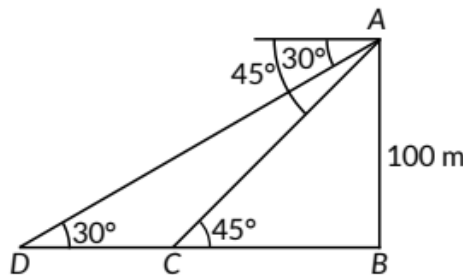

55. Let AB be the surface of the lake and C be the position of cloud and C' be its reflection or shadow in the lake. Also, let height of cloud is h m

Here, PM = AB and BM = AP = 60 m

= AP = 60 m

In  $\triangle PCM$ ,

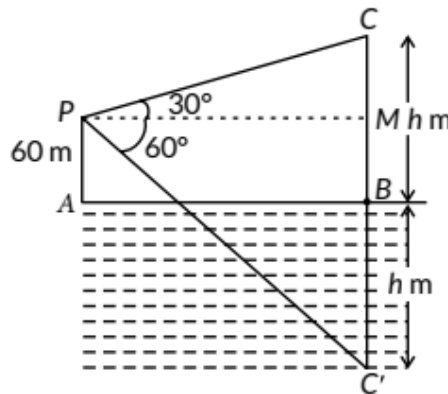

$$\tan 30^\circ = \frac{CM}{PM} = \frac{BC - BM}{AB} \quad [\because PM = AB]$$

$$\Rightarrow \frac{1}{\sqrt{3}} = \frac{h - 60}{AB}$$

$$\Rightarrow AB = (h - 60)\sqrt{3} \quad \dots(i)$$

$$\text{In } \triangle PMC', \tan 60^\circ = \frac{C'M}{PM} = \frac{BC' + BM}{AB}$$

$$\Rightarrow \sqrt{3} = \frac{h + 60}{AB} \Rightarrow AB = \frac{h + 60}{\sqrt{3}} \quad \dots(ii)$$

From (i) and (ii), we have

$$(h - 60)\sqrt{3} = \frac{h + 60}{\sqrt{3}}$$

$$\Rightarrow 3h - 180 = h + 60$$

$$\Rightarrow 2h = 240 \Rightarrow h = 120$$

Thus, height of the cloud from the surface of water is 120 m.



56.

Let CD be the tower.

In  $\triangle ADC$ ,

$$\tan 60^\circ = \frac{CD}{AD} = \frac{15}{AD}$$

$$\Rightarrow \sqrt{3} = \frac{15}{AD}$$

$$\Rightarrow AD = \frac{15}{\sqrt{3}} = 5\sqrt{3} \text{ m}$$

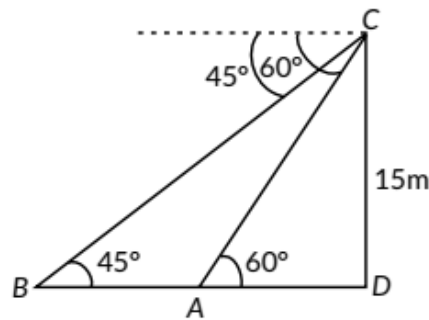

In  $\triangle BDC$ ,

$$\tan 45^\circ = \frac{CD}{BD} = \frac{15}{BD} \Rightarrow 1 = \frac{15}{BD} \Rightarrow BD = 15 \text{ m}$$

Distance between A and B =  $AB = BD - AD$

$$= 15 - 5\sqrt{3} = 15 - 8.66 = 6.34 \text{ m}$$

57. Let A be the position of aeroplane from the ground such that  $AB = 300 \text{ m}$  and C, D be two points on both banks of river in opposite directions.

In  $\triangle ABC$ ,

$$\tan 45^\circ = \frac{AB}{BC}$$

$$\Rightarrow 1 = \frac{300}{BC}$$

$$\Rightarrow BC = 300 \text{ m}$$

In  $\triangle ABD$ ,  $\tan 60^\circ = \frac{AB}{BD}$

$$\Rightarrow \sqrt{3} = \frac{300}{BD} \Rightarrow BD = \frac{300}{\sqrt{3}} = 100\sqrt{3} \text{ m}$$

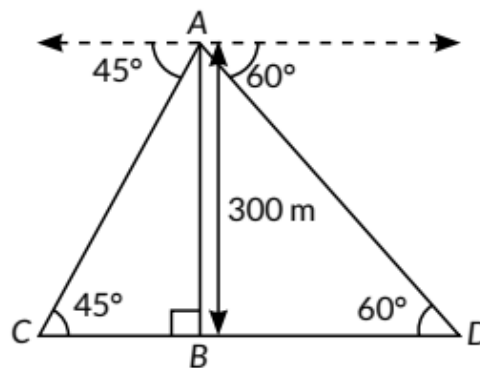

Width of river =  $CD = BC + BD$

$$= 300 + 100\sqrt{3} = 300 + 173.2 = 473.2 \text{ m}$$

58. Let initially the bird is at A and after two seconds it will be at position B.

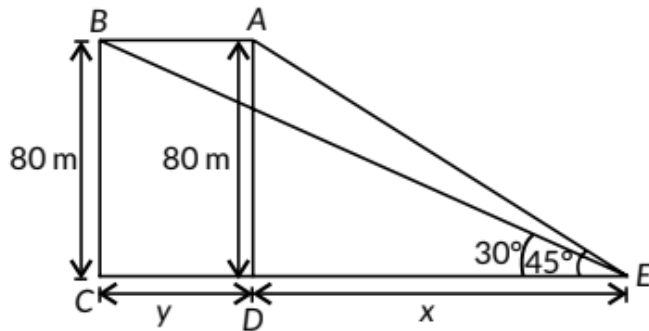

In  $\triangle ADE$ ,

$$\frac{AD}{DE} = \tan 45^\circ \Rightarrow \frac{80}{x} = 1 \Rightarrow x = 80 \text{ m}$$

$$\text{In } \triangle BCE, \frac{BC}{CE} = \tan 30^\circ \Rightarrow \frac{80}{x+y} = \frac{1}{\sqrt{3}}$$

$$\Rightarrow y = 80\sqrt{3} - 80 = 80(\sqrt{3} - 1) = 80(0.732) = 58.56 \text{ m}$$

Hence, bird covers the distance 58.56 m in 2 sec.

$$\therefore \text{Speed of bird} = \frac{58.56}{2} = 29.28 \text{ m/sec}$$

59. Let the height of the tower be  $AB = h$  m and C, D are the observation points.

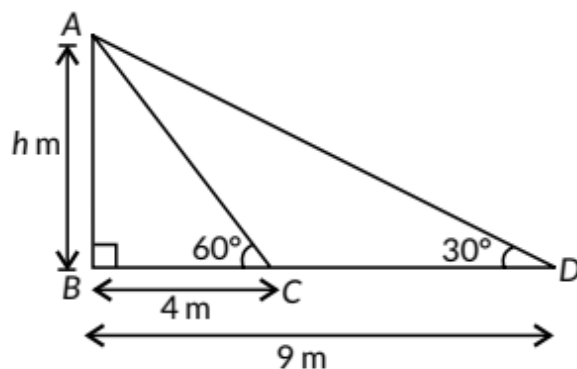

$$\text{In } \triangle ABC, \tan 60^\circ = \frac{h}{4} \Rightarrow h = 4\sqrt{3} \text{ m}$$

$$\text{In } \triangle ABD, \tan 30^\circ = \frac{h}{9} \Rightarrow h = \frac{9}{\sqrt{3}} = 3\sqrt{3} \text{ m}$$

Since height of tower is not unique from the given data.

$\therefore$  Question is wrong.

60. Let AB be the light house and y be distance travelled by ship during the period of observation.

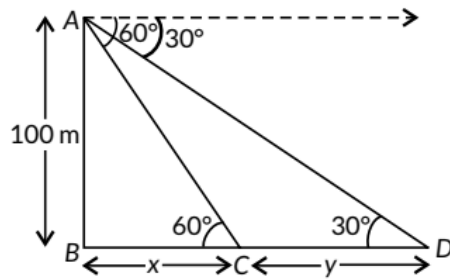

$$\text{In } \triangle ABC, \tan 60^\circ = \frac{AB}{BC} \Rightarrow \sqrt{3} = \frac{100}{x} \Rightarrow x = \frac{100}{\sqrt{3}} \quad \dots(i)$$

$$\text{In } \triangle ABD, \tan 30^\circ = \frac{100}{x+y}; \frac{1}{\sqrt{3}} = \frac{100}{x+y} \Rightarrow x+y = 100\sqrt{3}$$

$$\therefore y = 100\sqrt{3} - \frac{100}{\sqrt{3}} \quad \text{(Using (i))}$$

$$\Rightarrow y = \frac{300 - 100}{\sqrt{3}} = \frac{200}{\sqrt{3}} = 115.61 \text{ m}$$

61. Let AB be the tower of height h.

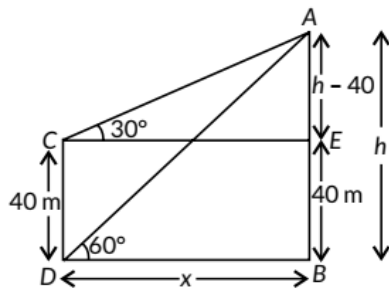

$$\begin{aligned} \text{In } \triangle ADB, \tan 60^\circ &= \frac{AB}{BD} \\ \Rightarrow \sqrt{3} &= \frac{h}{x} \therefore x = \frac{h}{\sqrt{3}} \quad \dots(i) \end{aligned}$$

$$\begin{aligned} \text{In } \triangle AEC, \tan 30^\circ &= \frac{AE}{CE} \\ \frac{1}{\sqrt{3}} &= \frac{h-40}{x} \Rightarrow x = \sqrt{3}(h-40) \quad \dots(ii) \end{aligned}$$

From (i) and (ii), we get

$$\frac{h}{\sqrt{3}} = \sqrt{3}(h-40) \Rightarrow h = 3(h-40)$$

$$\Rightarrow h = 3h - 120 \Rightarrow 2h = 120 \Rightarrow h = 60$$

$\therefore$  Height of tower (h) = 60 m and horizontal distance

$$\text{from point of observation (x)} = \frac{60}{\sqrt{3}} = 20\sqrt{3} \text{ m}$$

62. Let AB be the tower of height  $h$  m and AD be the flagstaff and C be the point on the ground at the distance of  $x$  m from the tower.

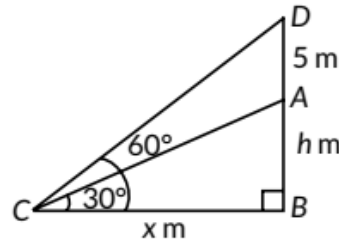

$$\text{In } \triangle CBD, \tan 60^\circ = \frac{BD}{BC} = \frac{h+5}{x}$$

$$\Rightarrow \sqrt{3}x = h+5 \Rightarrow \sqrt{3}x - 5 = h \quad \dots(i)$$

$$\text{In } \triangle ABC, \tan 30^\circ = \frac{AB}{BC} = \frac{h}{x}$$

$$\Rightarrow \frac{1}{\sqrt{3}} = \frac{h}{x} \Rightarrow x = \sqrt{3}h$$

$$\Rightarrow x = \sqrt{3}(\sqrt{3}x - 5) \quad \text{[Using (i)]}$$

$$\Rightarrow x = 3x - 5\sqrt{3} \Rightarrow x = \frac{5\sqrt{3}}{2} = 4.33$$

$$\text{Now, from (i), } h = \sqrt{3} \left( \frac{5\sqrt{3}}{2} \right) - 5 = 7.5 - 5 = 2.5$$

Hence, height of the tower is 2.5 m and distance of point from the tower is 4.33 m.

63. Let DE be the level of water and cloud be at position B which is  $h$  m above the level of water and reflection of cloud be at F and  $AC = DE = x$  m.

$\therefore BC = (h-20)$  m,  $CF = (h+20)$  m

$$\text{In } \triangle ABC, \tan 30^\circ = \frac{BC}{AC}$$

$$\Rightarrow \frac{1}{\sqrt{3}} = \frac{h-20}{x} \Rightarrow x = \sqrt{3}(h-20) \quad \dots(i)$$

$$\text{In } \triangle ACF, \tan 60^\circ = \frac{CF}{AC}$$

$$\Rightarrow \sqrt{3} = \frac{h+20}{x}$$

$$\Rightarrow x = \frac{h+20}{\sqrt{3}} \quad \dots(ii)$$

From (i) and (ii), we get

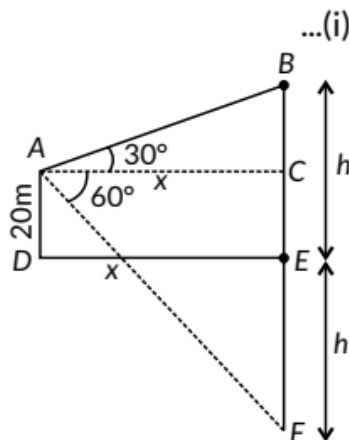

$$\sqrt{3}(h-20) = \frac{h+20}{\sqrt{3}}$$

$$\Rightarrow 3h - 60 = h + 20 \Rightarrow 2h = 80 \Rightarrow h = 40$$

$$\text{From (i), we have } x = \sqrt{3}(40 - 20) = 20\sqrt{3}$$

Applying Pythagoras theorem in  $\triangle ABC$ ,

$$AB^2 = BC^2 + AC^2 = (20)^2 + (20\sqrt{3})^2$$

$$= 400 + 1200 = 1600 \Rightarrow AB = \sqrt{1600} = 40 \text{ m}$$

$\therefore$  Distance of the cloud from point A = 40 m

64. Let AB be the building and CD be the tower. In right  $\triangle ABD$ ,

$$\tan 60^\circ = \frac{AB}{BD} \Rightarrow \sqrt{3} = \frac{60}{BD} \Rightarrow BD = \frac{60}{\sqrt{3}} = 20\sqrt{3} \text{ m}$$

In right  $\triangle ACE$ ,

$$\tan 30^\circ = \frac{CE}{AE} = \frac{CE}{20\sqrt{3}}$$

$$(\because AE = BD = 20\sqrt{3})$$

$$\Rightarrow \frac{1}{\sqrt{3}} = \frac{CE}{20\sqrt{3}} \Rightarrow CE = 20 \text{ m}$$

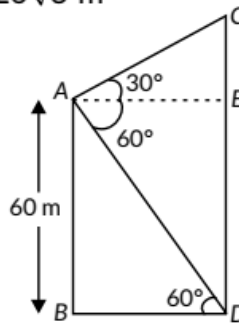

Difference between the heights of the tower and the building = 20 m

Distance between the tower and the building

$$= BD = 20\sqrt{3} \text{ m}$$

65.

Let  $BD = h$  be the total height of tower and flagstaff

$\therefore$  In  $\triangle DBA$ ,

$$\tan 60^\circ = \frac{h}{120}$$

$$\Rightarrow h = 120\sqrt{3} \text{ m}$$

and in  $\triangle CBA$ ,

$$\tan 45^\circ = \frac{CB}{120}$$

$$\Rightarrow CB = 120 \text{ m}$$

$\therefore$  Height of flagstaff,  $DC = DB - BC$

$$= 120\sqrt{3} - 120 = 120(\sqrt{3} - 1)$$

$$= 120(1.73 - 1) = 120(0.73) = 87.6 \text{ m}$$

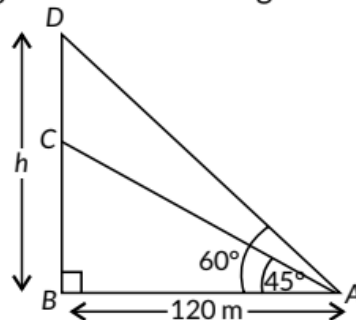

$$[\because \tan 45^\circ = 1]$$

66.

Let  $AB$  be the tower and  $CD = x$  be the height of chimney.

In  $\triangle ABD$ ,

$$\tan 30^\circ = \frac{AB}{BD}$$

$$\Rightarrow \frac{1}{\sqrt{3}} = \frac{40}{BD}$$

$$\Rightarrow BD = 40\sqrt{3} \text{ m}$$

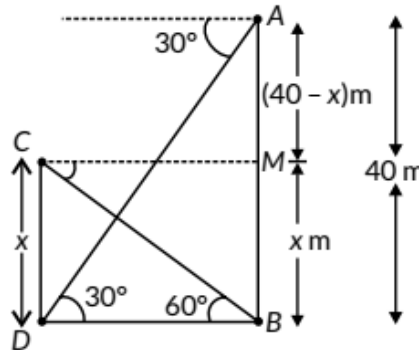

$$\text{In } \triangle BCD, \tan 60^\circ = \frac{CD}{DB} \Rightarrow \sqrt{3} = \frac{x}{40\sqrt{3}}$$

$$\Rightarrow x = 40 \times 3 = 120 \text{ m} \therefore \text{Height of chimney} = 120 \text{ m}$$

Yes, height of chimney meets the mentioned norms.

Values : Regulation of rules/norms and taking care of environment.

### CBSE Sample Questions

1.

Let  $PQ$  and  $RS$  be two poles of height  $y$  m and  $x$  m respectively.

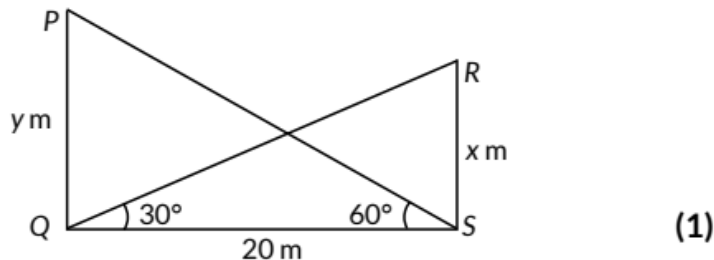

$$\text{In } \triangle PQS, \tan 60^\circ = \frac{y}{20} \Rightarrow y = 20\sqrt{3} \quad (1/2)$$

$$\text{In } \triangle RSQ, \tan 30^\circ = \frac{x}{20} \Rightarrow x = \frac{20}{\sqrt{3}} \quad (1/2)$$

$$\Rightarrow y - x = 20\sqrt{3} - \frac{20}{\sqrt{3}} = \frac{40}{\sqrt{3}} = \frac{40\sqrt{3}}{3} = 23.09$$

$\therefore$  Difference between heights of pole is 23.09 m. (1)

2. Let PR be the height of building and AB be the height of boy.

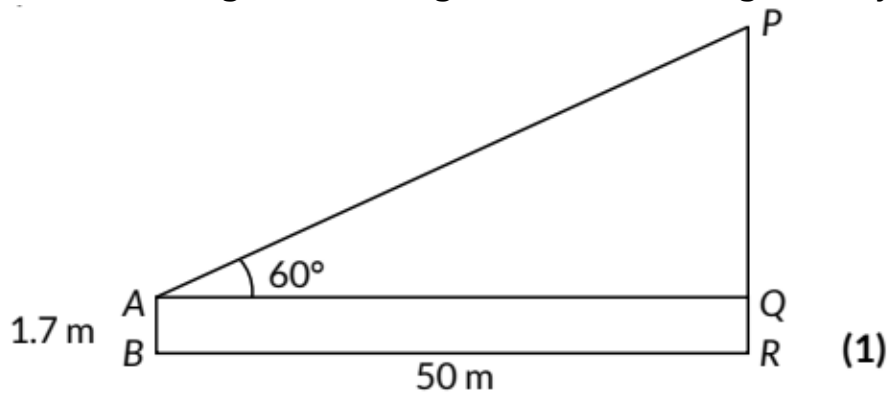

$$\text{In } \triangle PQA, \tan 60^\circ = \frac{PQ}{50} \Rightarrow PQ = 50\sqrt{3}\text{m} \quad (1)$$

$$\text{So, height of the building} = PR = (50\sqrt{3} + 1.7)\text{m} = 88.2\text{m} \quad (1)$$

3. Let AB be the candle of height  $h$  m and let C and D are two coins such that  $BC = b$  cm and  $BD = a$  cm. (1/2)

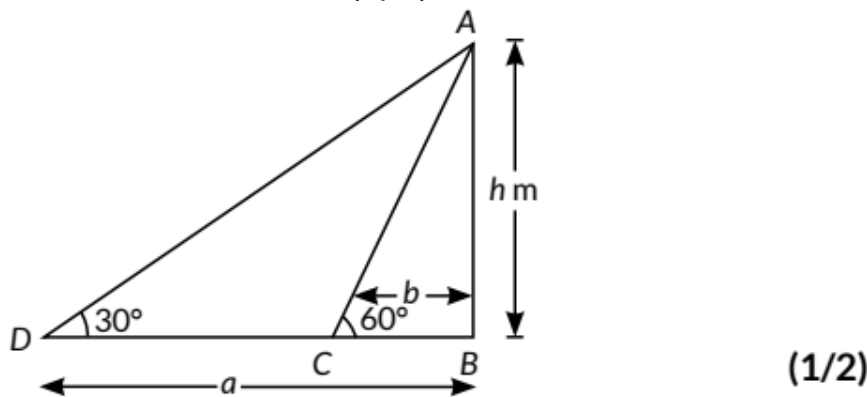

$$\text{In } \triangle ABC, \tan 60^\circ = \frac{AB}{BC} = \frac{h}{b}$$

$$\Rightarrow \sqrt{3} = \frac{h}{b} \Rightarrow h = b\sqrt{3} \quad \dots(i) \quad (1/2)$$

$$\text{In } \triangle ABD, \tan 30^\circ = \frac{AB}{BD} = \frac{h}{a}$$

$$\Rightarrow \frac{1}{\sqrt{3}} = \frac{h}{a} \Rightarrow h = \frac{a}{\sqrt{3}} \quad \dots(ii) \quad (1/2)$$

Multiplying (i) and (ii), we get

$$h^2 = b\sqrt{3} \times \frac{a}{\sqrt{3}} \quad (1/2)$$

$$\Rightarrow h^2 = ba \Rightarrow h = \sqrt{ab} \quad (1/2)$$

4. (i) Draw the figure as, where, P and Q are the two positions of the plane flying at a height of  $3000\sqrt{3}$  m. A is the point of observation from the ground.

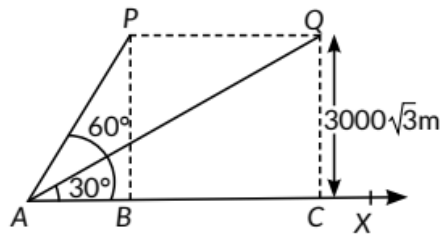

(1)

(ii) In  $\Delta PBA$ ,  $\tan 60^\circ = PB/AB$

$$\Rightarrow \sqrt{3} = 3000\sqrt{3} / AB$$

$$\text{So, } AB = 3000 \text{ m}$$

(1)

Now, in  $\Delta ACQ$ ,

$$\tan 30^\circ = QC/AC$$

$$\Rightarrow 1/\sqrt{3} = 3000\sqrt{3} / AC$$

$$\Rightarrow AC = 9000 \text{ m}$$

$$\text{Distance covered in 30 seconds} = AC - AB = 9000 - 3000 = 6000 \text{ m.}$$

(1)

OR

In  $\Delta PBA$ ,  $\tan 60^\circ = PB/AB$

$$\text{or } \sqrt{3} = 3000\sqrt{3} / AB$$

$$\text{So, } AB = 3000 \text{ m}$$

Now, in  $\Delta ADQ$

$$\tan 45^\circ = QD/AD$$

$$\Rightarrow 1 = 3000\sqrt{3} / AD$$

$$\Rightarrow AD = 3000\sqrt{3} \text{ m}$$

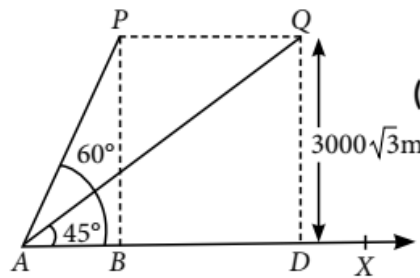

(1)

$$\text{Distance covered in } 15(\sqrt{3}-1) \text{ seconds} = AD - AB$$

$$= 3000\sqrt{3} - 3000 = 3000(\sqrt{3} - 1) \text{ m.}$$

(1)

$$\text{(iii) Speed} = \frac{\text{Distance}}{\text{Time}} = 6000/30 = 200 \text{ m/s}$$

$$= 200 \times 3600/1000 = 720 \text{ km/hr}$$

(1)

5. (i) Let TR be the height of tower and P be a point which represents the position of the boat. Let PR = xm



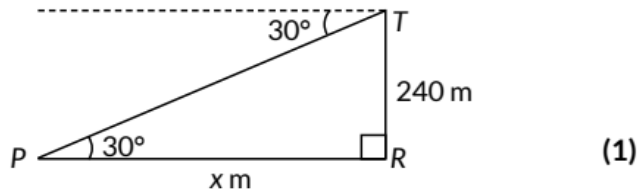

$$\text{In } \triangle PTR, \tan 30^\circ = \frac{240}{x} \Rightarrow x = 240\sqrt{3} \quad (1)$$

(ii) New distance of boat from tower  
 $= 240\sqrt{3} - 240(\sqrt{3} - 1) = 240 \text{ m} \quad (1)$

Let the new angle of depression be  $\theta$ .

$$\Rightarrow \tan \theta = \frac{240}{240} = 1 = \tan 45^\circ \Rightarrow \theta = 45^\circ \quad (1)$$

6. Let AB and CD be two palm trees of height  $h$  m. Let O be a point on river such that  $BO = x$  m, then  $OD = BD - BO = (80 - x)$  m.

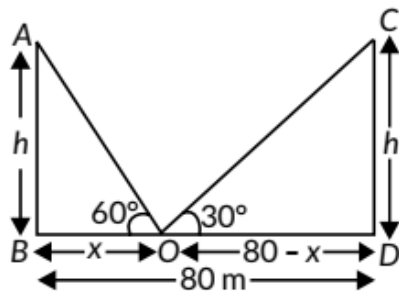

(1½)

Now, In  $\triangle ABO$ , we have

$$\frac{h}{x} = \tan 60^\circ \Rightarrow \sqrt{3} = \frac{h}{x}$$

$$\Rightarrow h = \sqrt{3}x \quad \dots(i) \quad (1)$$

Similarly, In  $\triangle CDO$ , we have

$$\frac{h}{80 - x} = \tan 30^\circ \Rightarrow h = \frac{1}{\sqrt{3}}(80 - x) \quad \dots(ii)$$

From (i) and (ii), we have

$$\sqrt{3}x = \frac{1}{\sqrt{3}}(80 - x) \Rightarrow 3x = 80 - x$$

$$\Rightarrow 4x = 80 \Rightarrow x = 20 \quad (1½)$$

Distance of point O from AB = 20 m (1/2)

Distance of point O from CD =  $80 - 20 = 60$  m (1/2)

Height of each tree,  $h = x\sqrt{3} = 20\sqrt{3}$   
 $= 20 \times 1.732 = 34.64$  m (1/2)

7. Let AB be the tower of height  $h$  m and CD be the building of height 50 m.  
(1/2)

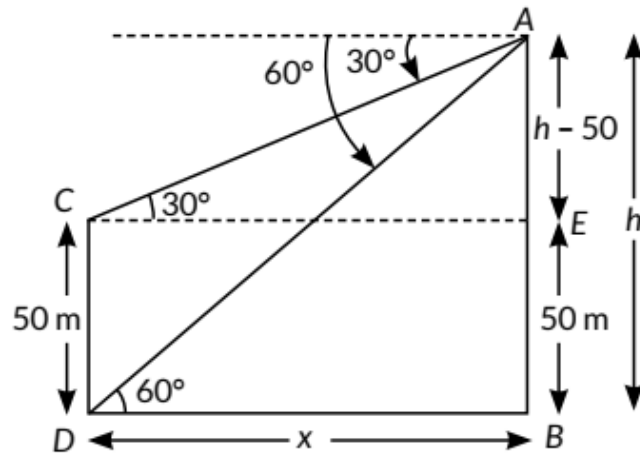

(1)

$$\text{In } \triangle ADB, \tan 60^\circ = \frac{AB}{BD}$$

$$\Rightarrow \sqrt{3} = \frac{h}{x} \therefore x = \frac{h}{\sqrt{3}} \quad \dots(i) \quad (1/2)$$

$$\text{In } \triangle ACE, \tan 30^\circ = \frac{AE}{CE}$$

$$\Rightarrow \frac{1}{\sqrt{3}} = \frac{h-50}{x} \quad (1/2)$$

$$\Rightarrow x = \sqrt{3}(h-50) \quad \dots(ii) \quad (1/2)$$

From (i) and (ii), we get

$$\frac{h}{\sqrt{3}} = \sqrt{3}(h-50)$$

$$\Rightarrow h = 3(h-50) \quad (1/2)$$

$$\Rightarrow h = 3h - 150$$

$$\Rightarrow 2h = 150 \Rightarrow h = 75 \quad (1/2)$$

and horizontal distance between the building and the

$$\text{tower } (x) = \frac{75}{\sqrt{3}}$$

$$= 25\sqrt{3} \text{ m} \quad (1/2)$$